

Owners Manual

Model #ABS1008-01B

AbSolo®

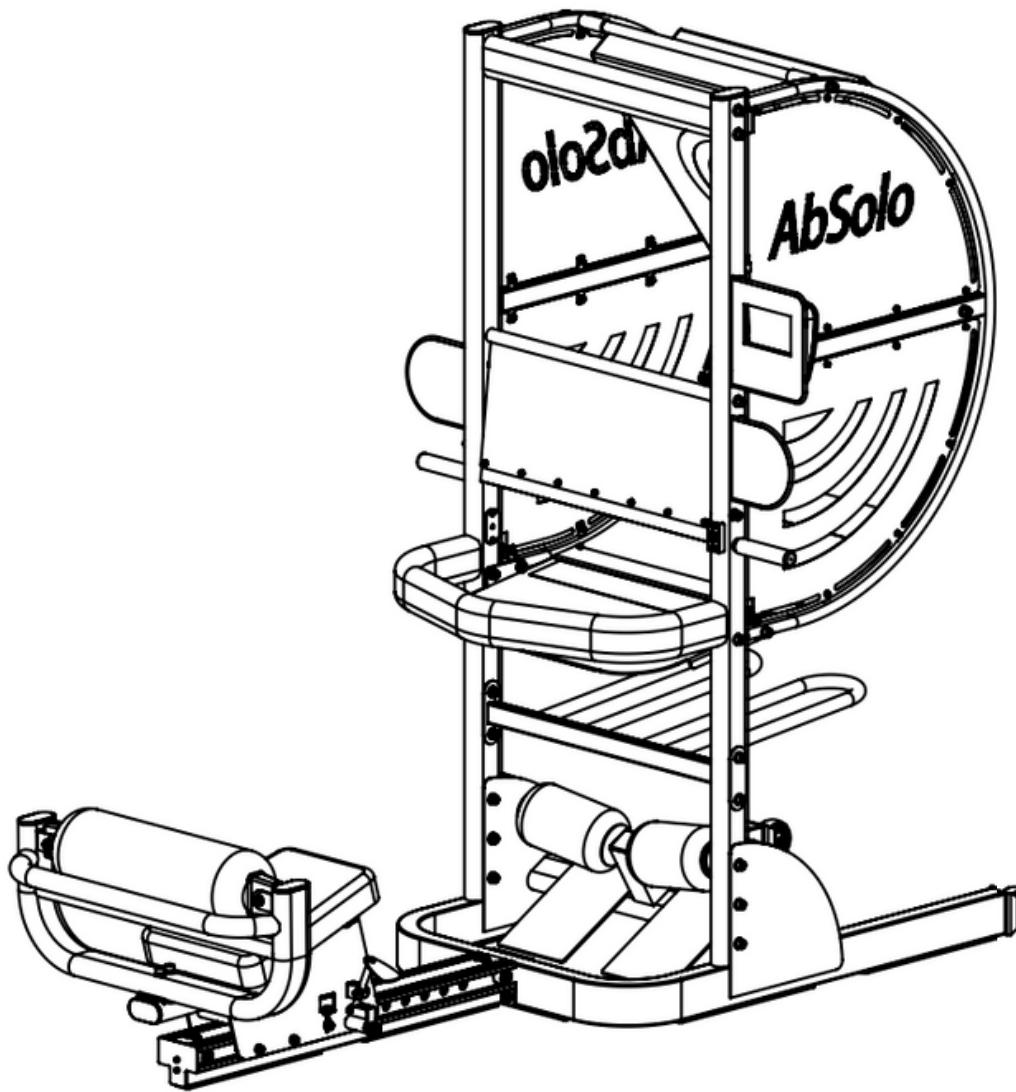

We Change Lives from the Core

Warranty information inside



TABLE OF CONTENTS

Important Safety Instructions.....	pg. 03
Instructions.....	pg. 04
Parts List.....	pg. 05
Exploded View.....	pg. 07
Hardware Kit.....	pg. 08
Measurement Guide.....	pg. 09
Assembly Instruction.....	pg. 10
Assembly.....	pg. 11
General Maintenance Schedule.....	pg. 23
General Maintenance Information.....	pg. 24
Training Tips.....	pg. 25
Warranty.....	pg. 26



CAUTION Read all precautions and instructions in the manual before using this equipment.

IMPORTANT SAFETY INSTRUCTIONS



Before beginning any fitness program, you should obtain a complete physical examination from your physician. When using exercise equipment, basic precautions should always be taken, including the following:

1. Read all instructions before using the equipment. These instructions are written to ensure your safety and to protect the unit.
2. Use the equipment only for its intended purpose as described in this guide. Do not use accessory attachments that are not recommended by the manufacturer, as such attachments might cause injuries.
3. The product should only be used on a level surface and with 0.5 meters space around the product. Do not store the equipment outdoors.
4. The equipment is not intended for use by children under the age of 16. Children over the age of 16 should use the equipment with adult supervision.
5. Do not overexert yourself or work to exhaustion. Do not attempt to lift more weight than you can control safely. If you feel any pain or abnormal symptoms, stop your workout immediately and consult your physician.
6. This equipment is not intended to be used as or with medical apparatus/instruments.
7. Never operate the unit when it has been dropped or damaged. Never drop or insert anything into any opening in the equipment. Always check the unit and its cables before each use. Make sure that all fasteners and cables are secure and in good working condition. Frayed or worn cables can be dangerous and may cause injury. Periodically check these cables for any indication of wear. Keep hands, limbs, loose clothing and long hair well out of the way of moving parts.
8. Be careful when getting on or off the equipment.
9. Wear proper exercise clothing and shoes for your workout, no loose clothing.

Personal Safety During Assembly

Read each step in the assembly instructions and follow the steps in sequence. Do not skip ahead. If you skip ahead, you may learn later that you have to disassemble components and that you may have damaged the equipment.

Assemble and operate the equipment on a solid, level surface. Locate the unit a few feet from walls or furniture to provide easy access. The equipment is designed for your enjoyment, and by following these precautions, we believe you will enjoy your new equipment and the many benefits it will provide.



INSTRUCTIONS

Before beginning assembly, please take the time to read instructions thoroughly. Please use the various lists in this manual to make sure that all parts have been included in your shipment. If parts are found to be missing, please contact either your authorized dealer or us directly and reference the part name and number from the parts list. Use only our replacement part when servicing. Failure to do so will void your warranty and could result in personal injury.

The equipment is designed to provide the smoothest, most effective exercise motion possible. After assembly, you should check all functions to ensure correct operation. If you experience problems, first recheck the assembly instructions to locate any possible errors made during assembly. If you are unable to correct the problem, call your authorized dealer or contact us directly to continue troubleshooting. Be sure to have the serial number, related part names and numbers and your manual handy when calling. Do not continue assembly, or use the equipment until all parts have been accounted for and troubleshooting is complete.

Tools Required



Ratchet Wrench and Socket



Adjustable Wrench

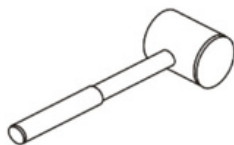

Rubber Mallet



Hex Key Wrench set



Phillips Screwdriver

PARTS LIST



NOTE: SOME OF THESE PARTS MAY COME PRE-INSTALLED

Item No.	Description	Qty	Item No.	Description	Qty
1	Base ASSY	1	32	Φ26*20*69 Spacer	2
2	Left Upright ASSY	1	33	Axle	1
3	Right Upright ASSY	1	34	Back Bumper	1
4	Ball Rack ASSY	1	35	Seat Pad	1
5	Leg ASSY	1	36	Φ120*200 Foams	2
6	Ball Block	1	37	Φ17*Φ13.5*Φ6*12 End Cap	2
7	Horizontal Bar	1	38	18*45M6 Adjustable Bolt	2
8	Baffle	1	39	30*11*1 U-Shaped Support	2
9	Lower Chute	1	40	Cloth Cover	1
10	Left /Right Small Support	2	41	Target	1
11	Fixed Tube Upper	1	42	Inner Baffle	1
12	Fixed Tube Lower	1	43	Chute Cover	1
13	Track Frame	1	44	Cover	1
14	Seat Support ASSY	1	45	Bushing	2
15	Support	1	46	360*80 Velcro Tape	1
16	Control Lever	1	47	540*80 Velcro Tape	3
17	Bladder Support ASSY	1	48	Switch Fixing Plate	1
18	Monitor Support	1	49	Receiver Fixing Plate	2
19	Slide Track	1	50	Receiver Base	1
20	Reinforcement Plate	2	51	Transmitter Base	1
21	Upper Chute	1	52	Monitor	1
22	Cover 100*83*3	1	53	Button	1
23	Baffle Cover 595*15*2	1	54	Button Wire 2	1
24	Enclosure Plate - Upper Left	1	55	Infrared Transmitting Wire 2	1
25	Enclosure Plate - Upper Right	1	56	Infrared Transmitting Wire 3	1
26	Enclosure Plate - Upper Lower	2	57	Infrared Transmitting Wire 4	1
27	Φ66*33 End Cap	2	58	Receiver	1
28	Rubber Pad 350*35*5	7	59	F50*2.5 Square End Cap	1
29	Φ28*26 Spacer	4	60	PT40*80*2 End Cap	5
30	Φ12*8.2*10 Spacer	8	61	Handle Cover	2
31	Φ26*20*59 Spacer	2	62	Wheel	8



PARTS LIST

NOTE: SOME OF THESE PARTS MAY COME PRE-INSTALLED

Item No.	Description	Qty
63	M20*1.5*15 Nut	1
64	M10 Nut	2
65	M6 Nut	2
66	Spring	1
67	Wheel Φ 75*40	2
68	End Cap PT15*30*1.5	4
69	Rubber Cushion	6
70	Bushing Φ 22*016*011	3
71	Foam Φ 65*31030	1
72	Φ 11*020*2 Washer	63
73	Φ 9*016*1.6 Washer	20
74	Φ 10 Spring Washer	21
75	M10 Nut	20
76	M8 Nut	10
77	M10*60 Bolt	32
78	M10*100 Bolt	1
79	M10*65 Bolt	1
80	M10*40 Bolt	1
81	M8*30 Bolt	1
82	Φ 8 Spring Washer	2
83	M8*15 Hex Bolt	1
84	M8*90 Hex Bolt	1
85	M10*35 Hex Bolt	1
86	M8*20 Hex Bolt	1
87	M6*12 Hex Screw	1
88	Φ 5.5*010*1 Washer	2
89	M5 Nut	2
90	M5*12 Hex Bolt	7
91	M5*20 Hex Bolt	4
92	M5*30 Hex Bolt	8
93	M5*10 Bolt	2



EXPLODED VIEW

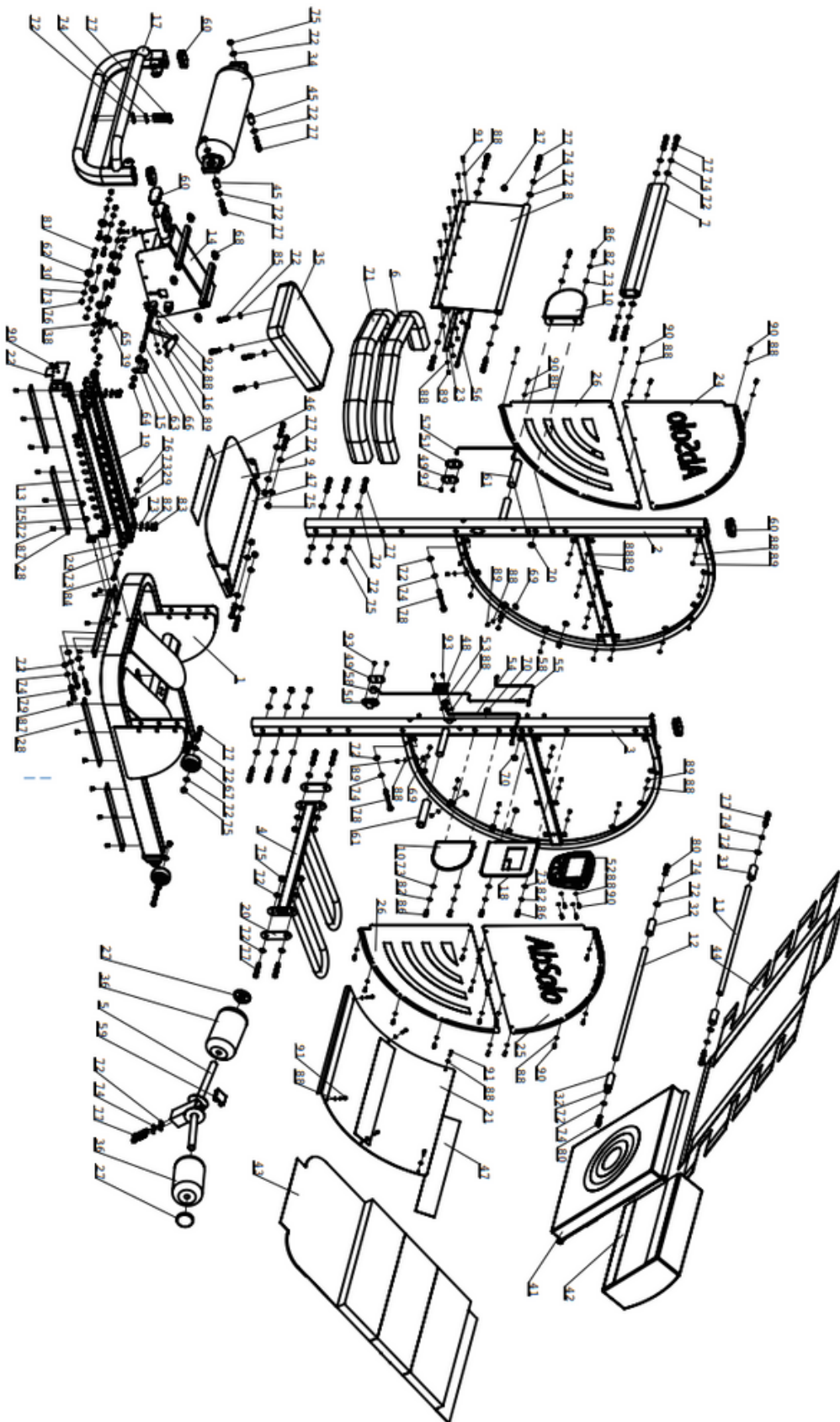

HARDWARE KIT

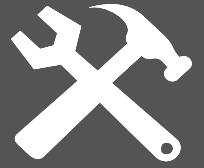

PARTS

- No. 79 M10X65 (3)
- No. 77 M10X60 (28)
- No. 72 Ø10 Washer (49)
- No. 80 M10X40 (2)
- No. 91 M5X20 (6)
- No. 90 M5X12 (4)
- No. 73 Ø8 Washer (6)
- No. 82 Ø8 Spring Washer (6)
- No. 88 Ø5 Washer (10)
- No. 89 M5 Nut (6)
- No. 86 M8X20 (6)
- No. 74 Ø10 Spring Washer (19)
- No. 75 M10 (16)
- No. 85 M10X35 (4)

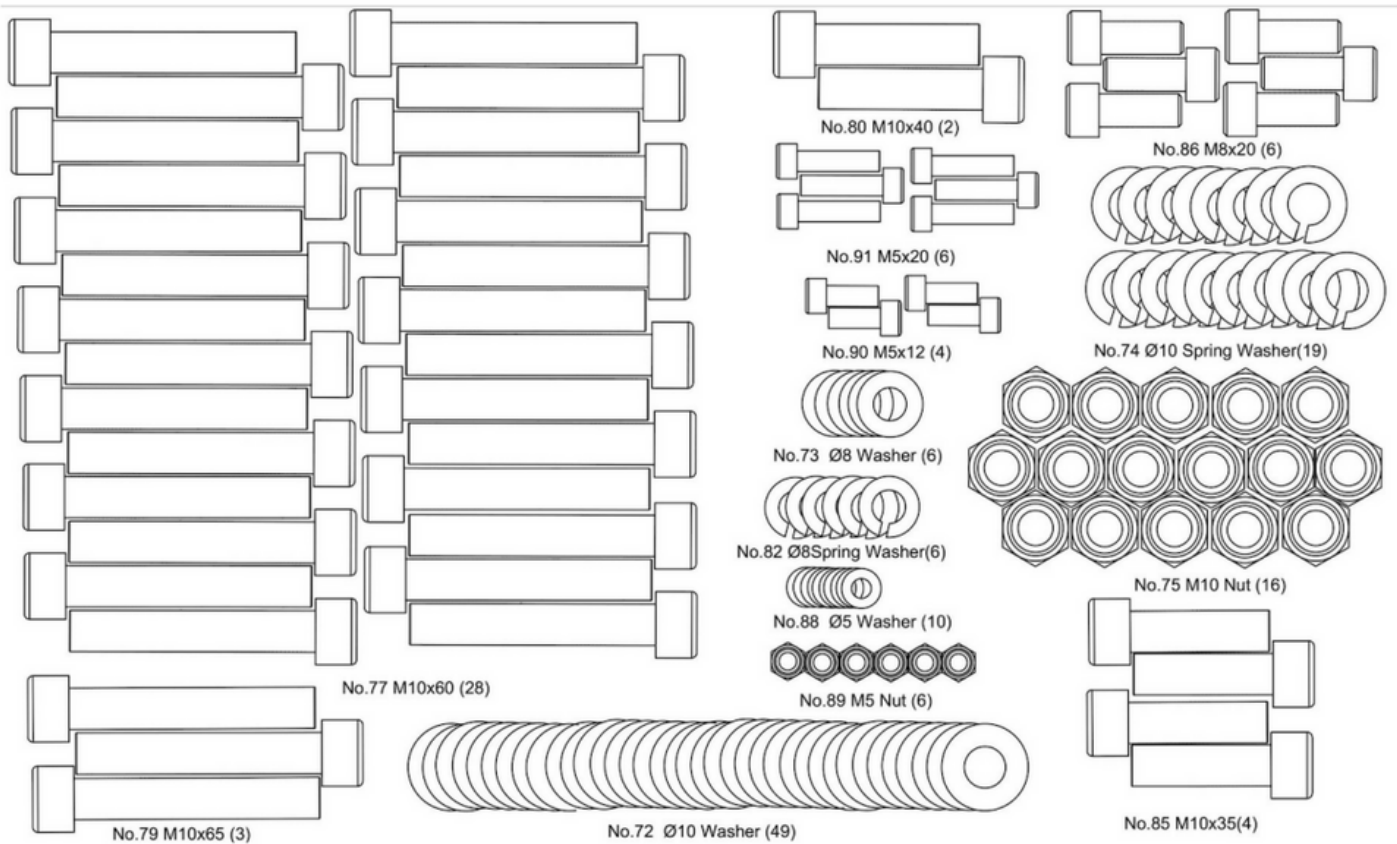

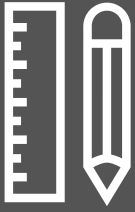

MEASUREMENT GUIDE

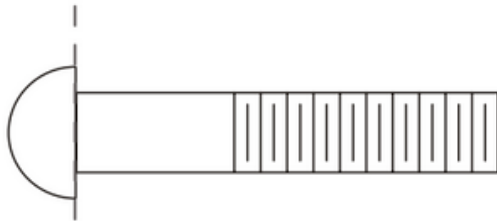

BHCB = Button Head Cap Bolt

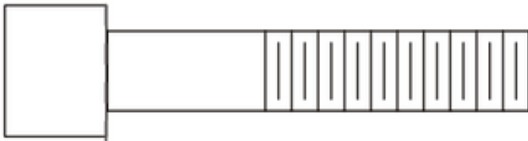

SHCB = Socket Head Cap Bolt

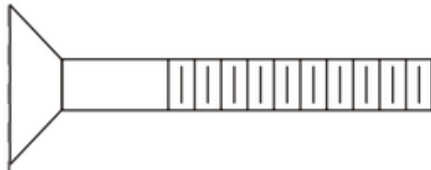

FHCB = Flat Head Cap Bolt

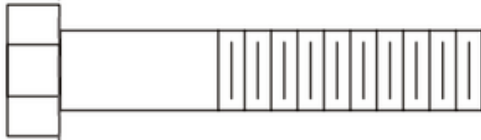

HHB = Hex Head Bolt

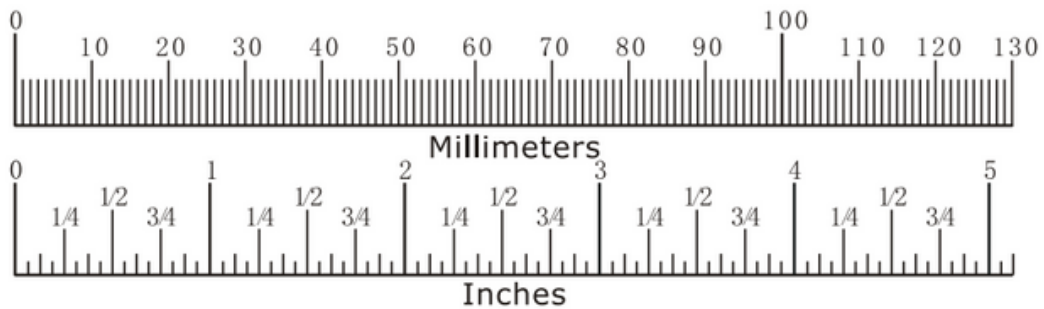

Diameter of bolt (mm/inch)	M6(1/4")	M8(5/16")	M10(3/8")	M12(1/2")	M16(5/8")
Tightening torque (N.m)	9~12	22~30	45~59	78~104	193~257
Operational methods for an adult	The strength of the wrist	The strength of the wrist and forearm	The strength of the entire arm	The strength of the arm and upper body	with all strength

ASSEMBLY INSTRUCTIONS



Assembly of the equipment takes professional installers about 1.5 hours. If this is the first time you have assembled this type of equipment, plan to spend more time. If you are in doubt about any part of this assembly, we recommend you contact a professional installer to complete the assembly. You may find it quicker, safer, and easier to assemble this equipment with the help of an assistant, as some components may be large, heavy or awkward to handle alone. It is important that you assemble your product in a clean, clear, uncluttered area. This will enable you to move around the product while you are fitting components and reduce the possibility of injury during assembly or damage to the area or equipment.



Note

As with any assembled part, proper alignment and adjustment is critical. While tightening the fasteners, be sure to leave room for adjustments. Do not fully tighten the fasteners until instructed to do so. Be careful to assemble the components in the sequence presented in this guide.

Training Area and Free Area

46 in / 117 cm

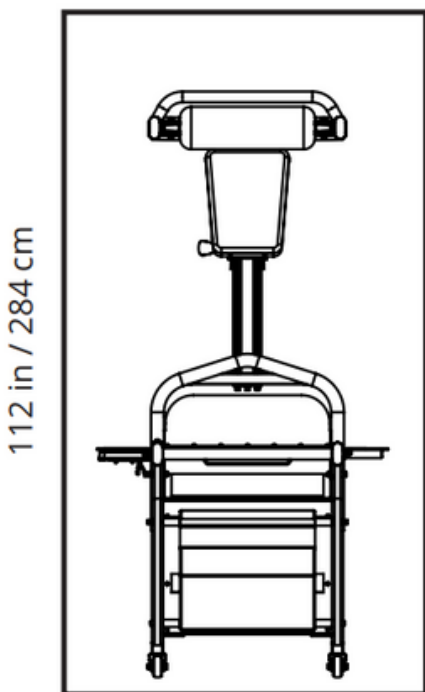

Free Area

Please allow for free area beyond the training area of 24 in / 60 cm on all sides of the unit to ensure that the training area is not impeded.

Specifications

Maximum Wt Capacity: 110 lbs / 50 kg

Maximum User Weight: 400 lbs / 180 kg

Product Total Surface: 40.5*74 in / 104*190 cm



ASSEMBLY

● STEP 1

1. Attach the Leg ASSY (#5) and the Seat Support ASSY (#13) to the Base ASSY (#1) using:
 - seven $\Phi 11 \times \Phi 20 \times 2$ Flat Washers (#72)
 - five $\Phi 10$ Spring Washers (#74)
 - two M10 Nylon Lock Nuts (#75)
 - three M10*65 Socket Head Cap Bolts (#79)
 - two M10*60 Socket Head Cap Bolts (#77)

Note: Tighten all connections from Step 1.

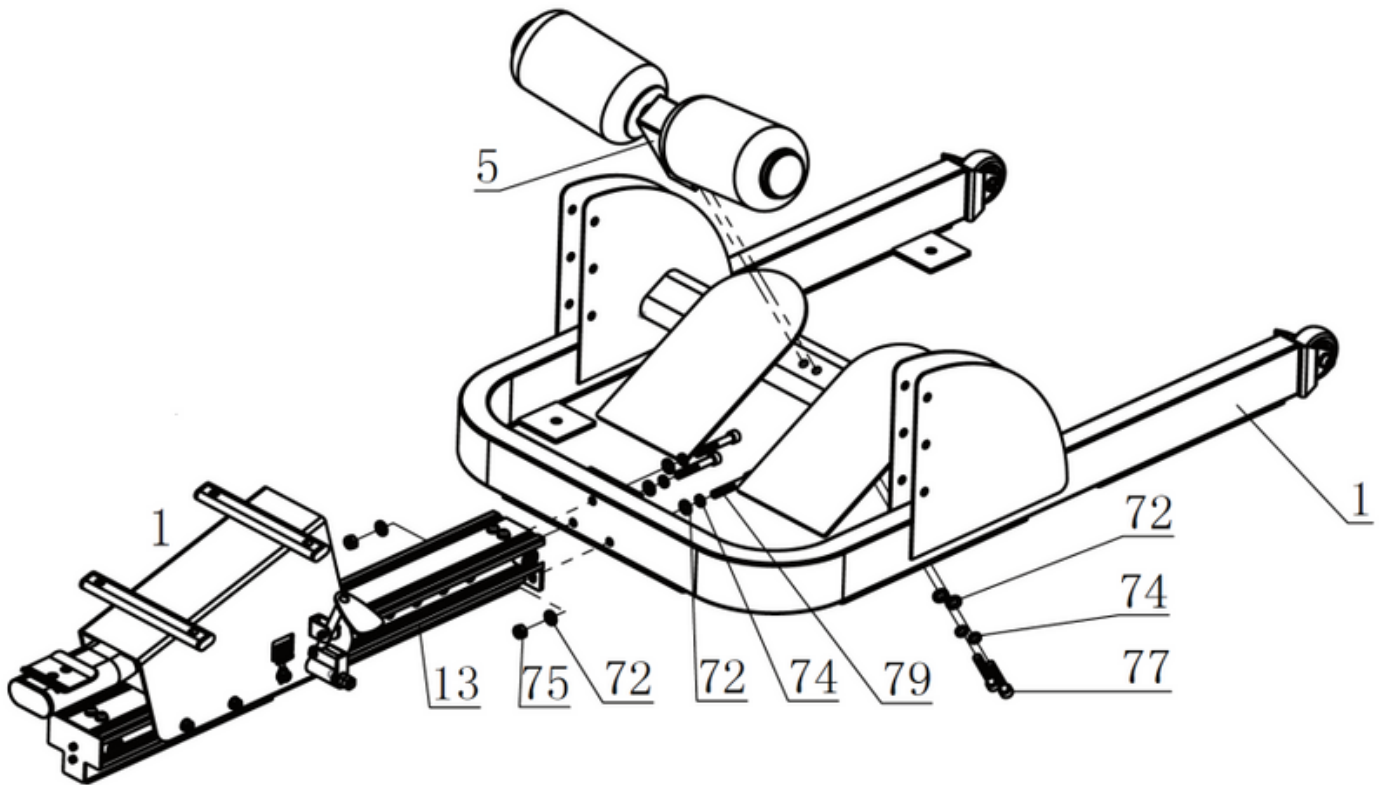



ASSEMBLY

● STEP 2

1. Attach the Left Upright ASSY (#2) and the Right Upright ASSY (#3) to the base ASSY (#1) using:
 - six M10*60 Socket Head Cap Bolts (#77)
 - twelve $\Phi 11*\Phi 20*2$ Flat Washers (#72)
 - six M10 Nylon Lock Nuts (#75)

Note: Secure the uprights to the base but do not fully tighten yet.

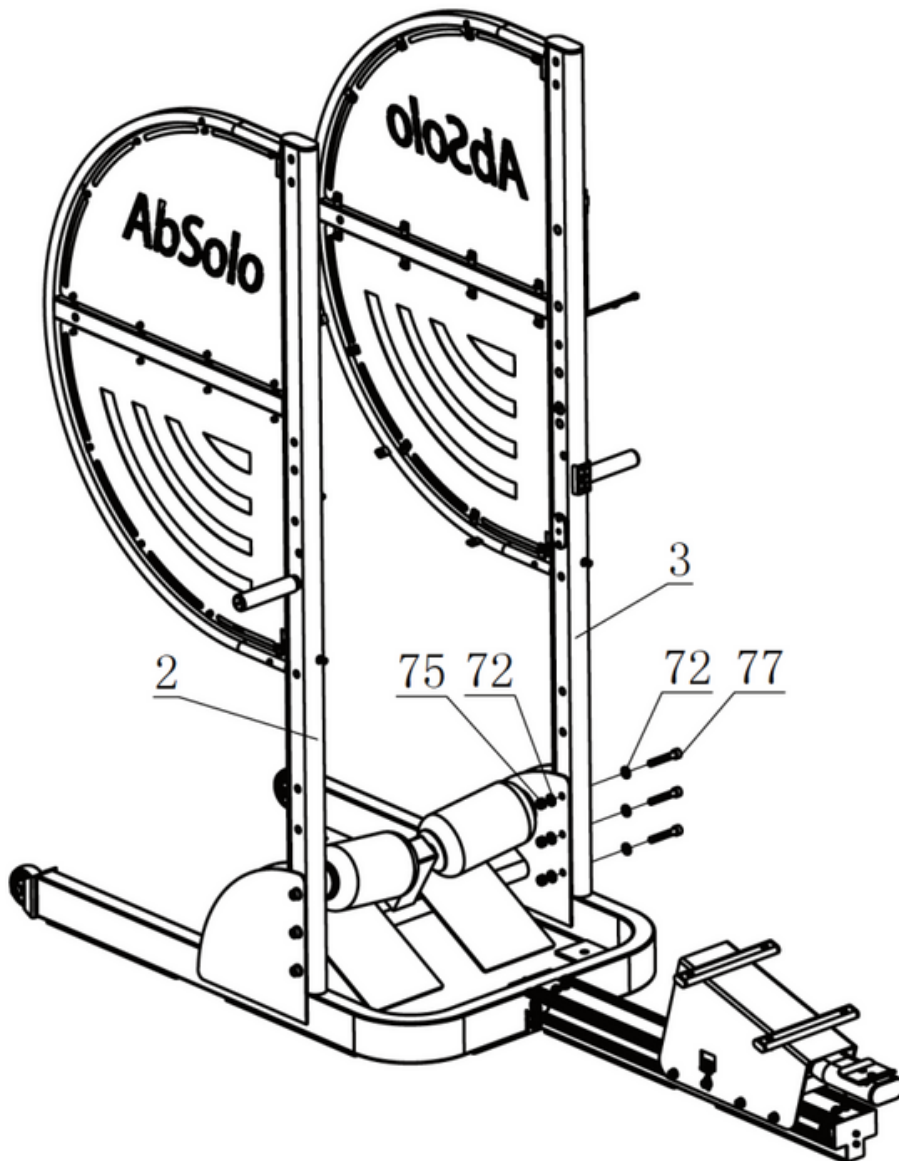



ASSEMBLY

● STEP 3

1. Attach Ball Rack (#4) to the both sides of the Uprights using:

- two M10 Nylon Lock Nuts (#75)
- two Reinforcement Plates (#20)
- four M10*60 Socket Head Cap Bolts (#77)
- eight $\Phi 11 \times \Phi 20 \times 2$ Flat Washers (#72)
- four M10 Nylon Lock Nuts (#75)

Note: Secure to the uprights but do not fully tighten yet.

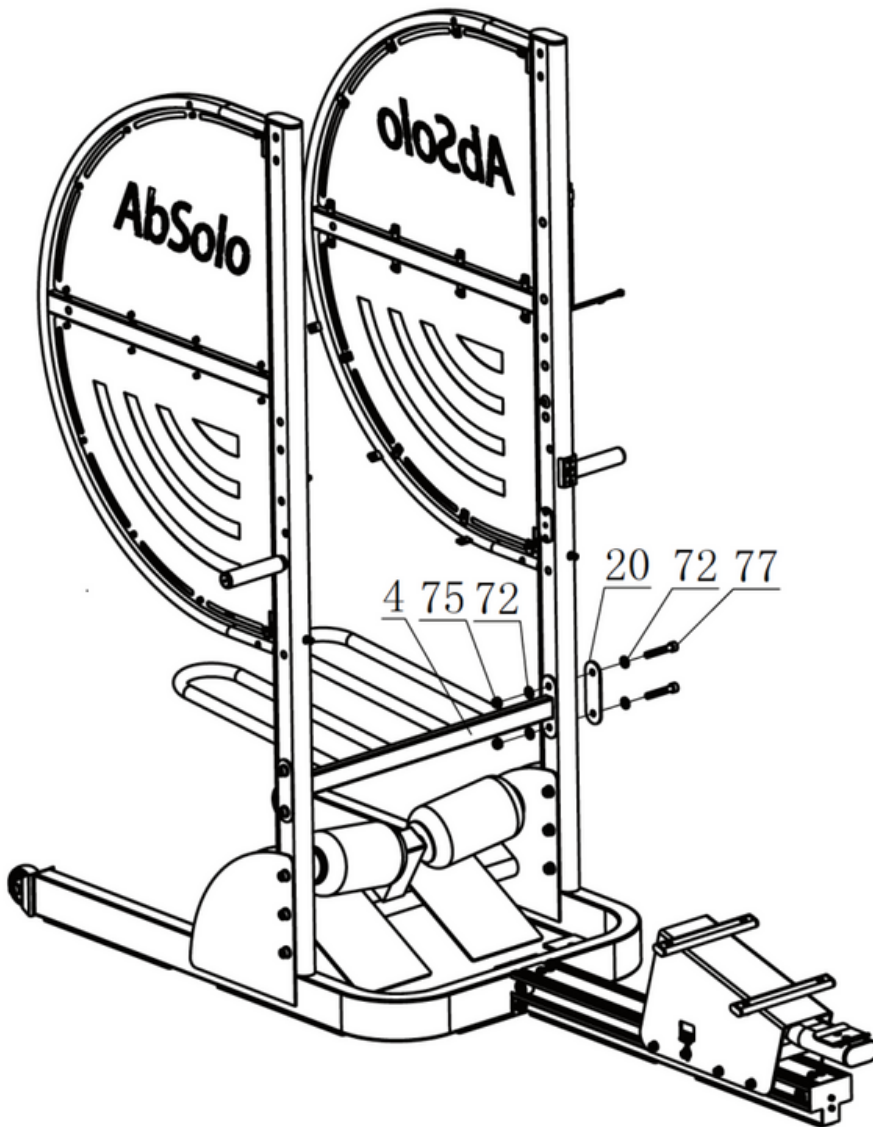



ASSEMBLY

● STEP 4

1. Attach Upper Chute (#21) being sure to orient the downward facing lip closest to the Uprights. Be sure to place the Rubber Cushions (#69) between the Upper Chute (#21) and the Uprights Mount points using:
 - six M5*20 Socket Head Cap Bolts (#91)
 - twelve $\Phi 5.5 \times \Phi 10 \times 1$ Flat Washers (#88)
 - six $\Phi 9 \times \Phi 19 \times 3$ Rubber Cushions (#69)
 - six M5 Nylon Locking Nut (#89)

Note: Tighten all connections from Step 4.

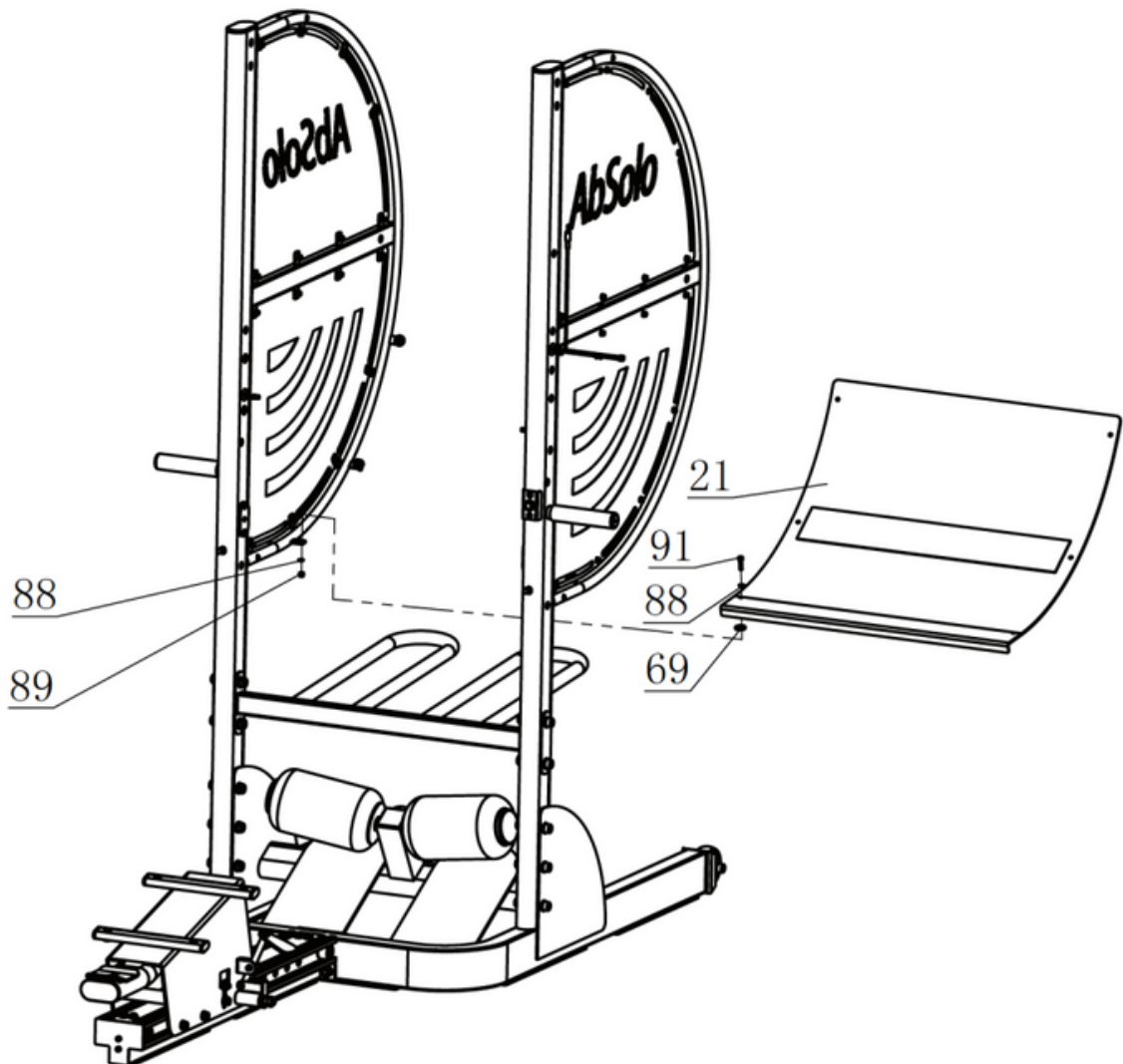



ASSEMBLY

STEP 5

1. Attach Lower Chute (#9) to the Uprights ASSY using:

- four M10*60 Socket Head Cap Bolts (#77)
- eight $\Phi 11 \times \Phi 20 \times 2$ Flat Washers (#72)
- four M10 Nylon Lock Nuts (#75)

Note: Secure to the uprights but do not fully tighten yet.

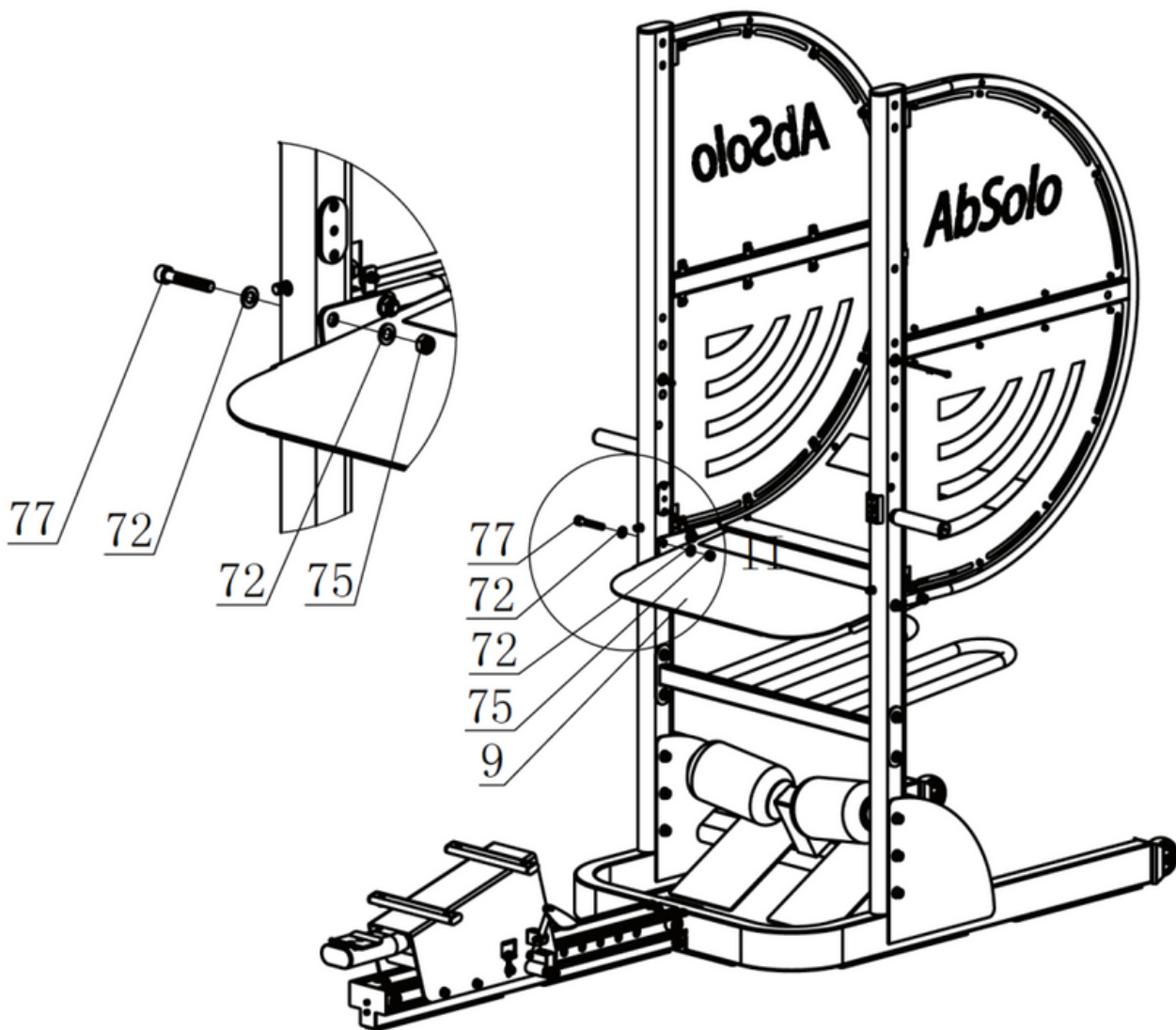



ASSEMBLY

● STEP 6

1. Attach Ball Block (#6) to the Uprights ASSY using:

- two M10*100 Socket Head Cap Bolts (#78)
- two $\Phi 10$ Spring Washers (#74)
- two $\Phi 11*\Phi 20*2$ Flat Washers (#72)

Note: Secure to the uprights but do not fully tighten yet.

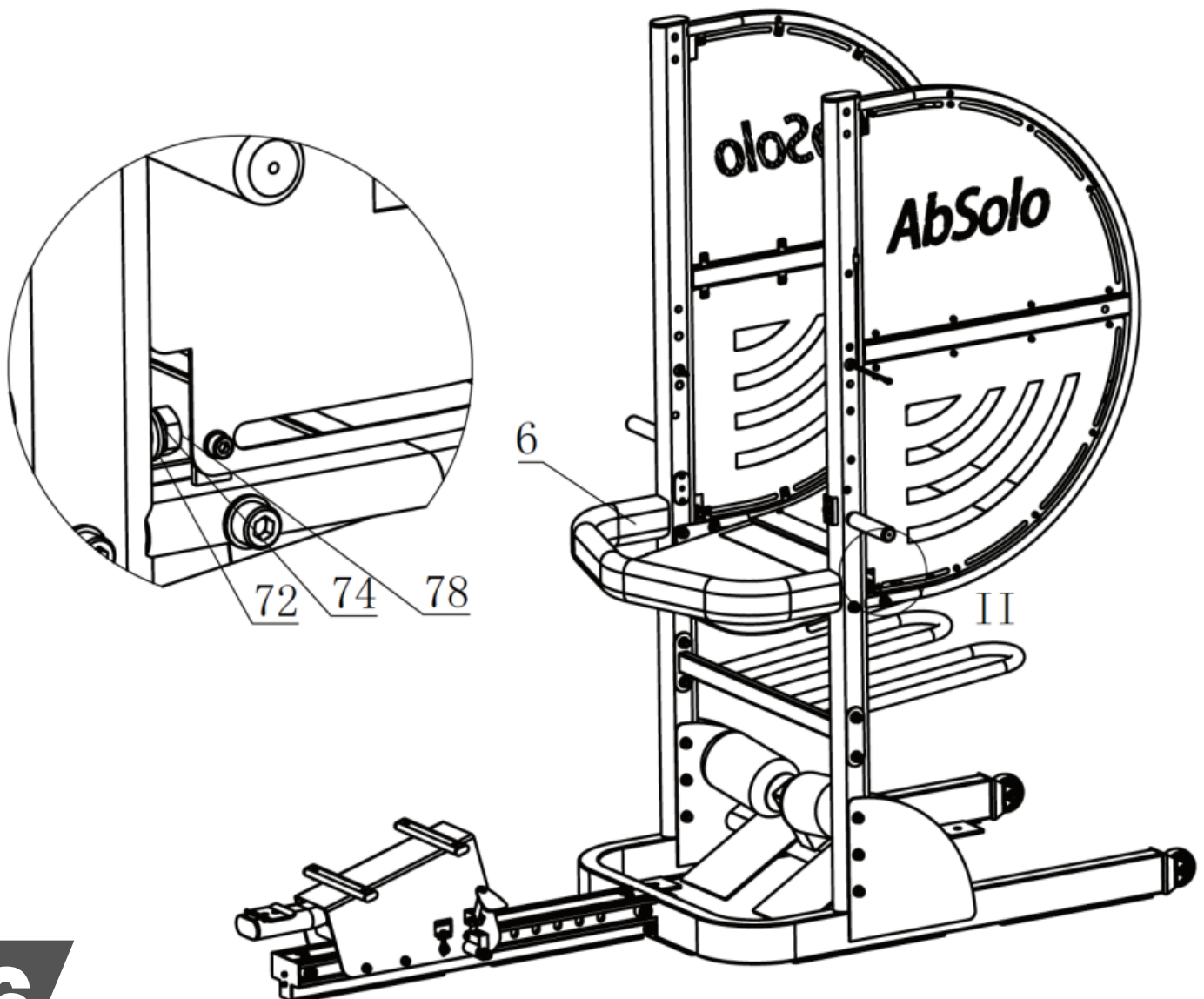



ASSEMBLY

● STEP 7

1. Attach Bull's Eyes Baffle (#8) to the Uprights ASSY using:

- four M10*60 Socket Head Cap Bolts (#77)
- four Φ 10 Spring Washers (#74)
- four Φ 11* Φ 20*2 Flat Washers (#72)

Note: Secure to the uprights but do not fully tighten yet.

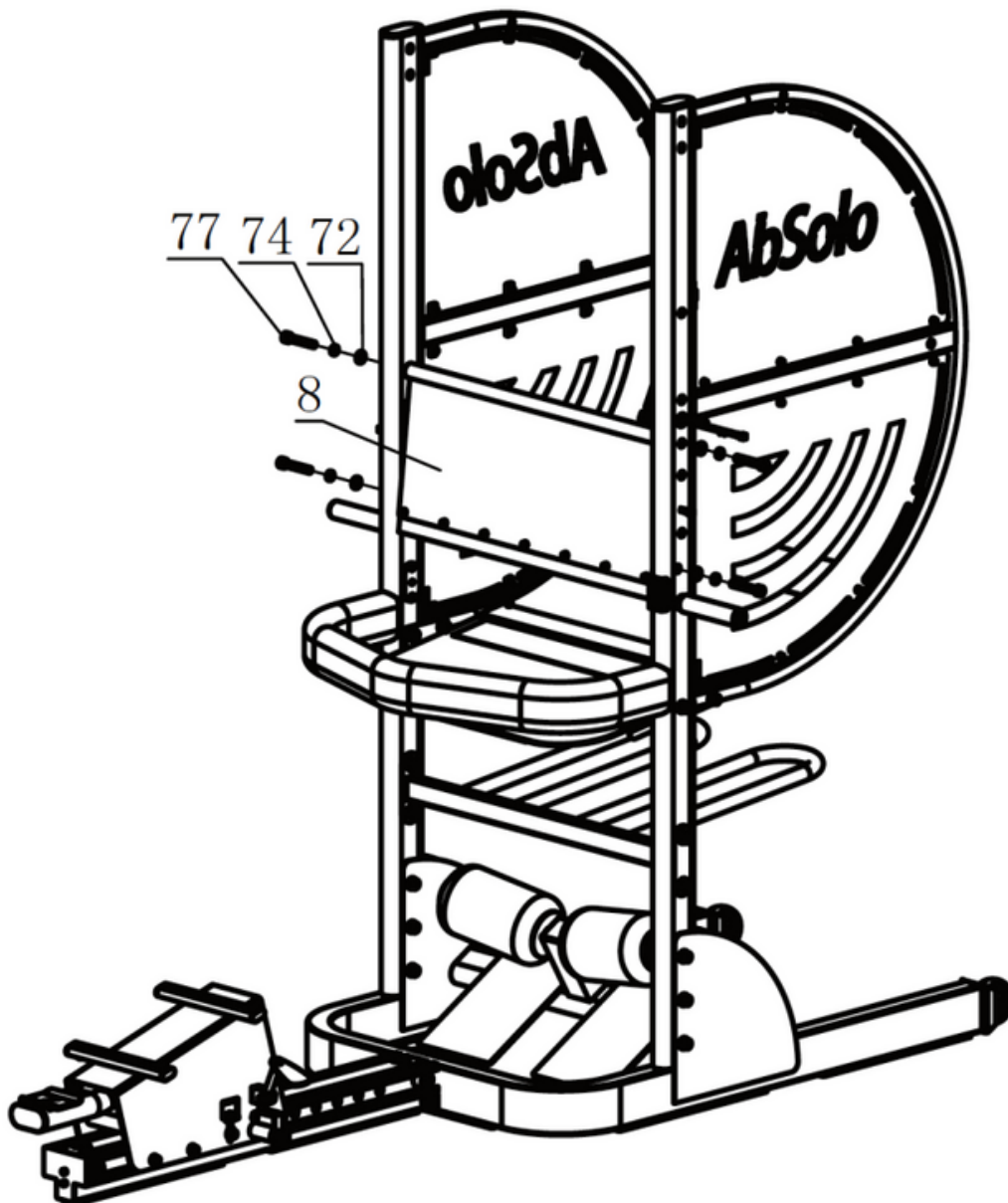



ASSEMBLY

● STEP 8

1. Attach Horizontal Top Bar (#7) to the Uprights ASSY using:

- four M10*60 Socket Head Cap Bolts (#77)
- four Φ 10 Spring Washers (#74)
- four Φ 11* Φ 20*2 Flat Washers (#72)

Note: Now go back and securely tighten all the connections in Steps 2-8.

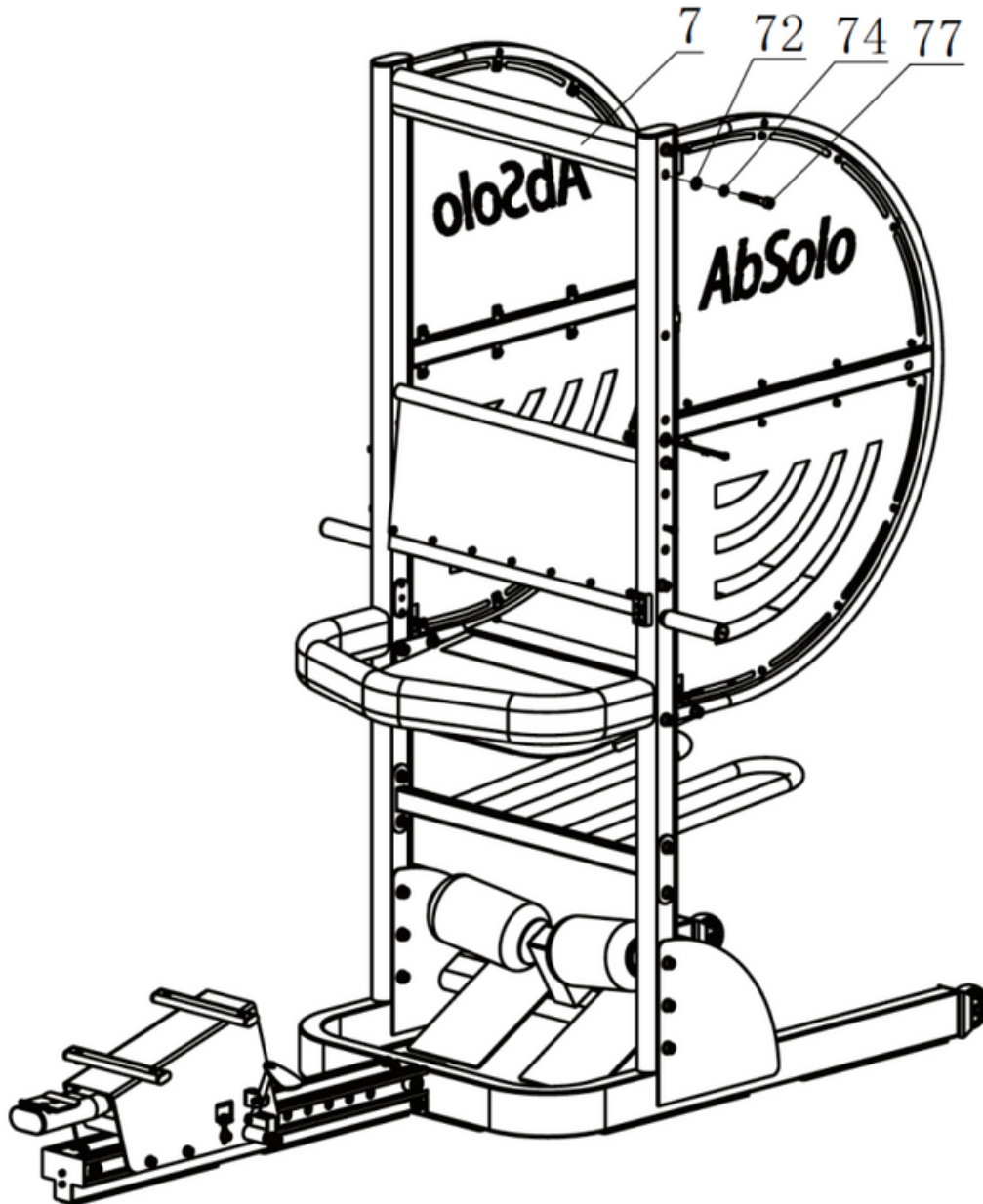



ASSEMBLY

● STEP 9

1. Attach the Target (#41) to the Uprights ASSY with Upper Tube (#11) using:

- two $\Phi 26 \times \Phi 20 \times 59$ Upper Spacer (#31)
- two $\Phi 10$ Spring Washers (#74)
- two $\Phi 11 \times \Phi 20 \times 2$ Flat Washers (#72)
- two M10*60 Socket Head Cap Bolts (#77)

2. Attach the Target (#41) to the Uprights ASSY with Lower Tube (#12) using:

- two $\Phi 26 \times \Phi 20 \times 59$ Upper Spacer (#31)
- two $\Phi 26 \times \Phi 20 \times 69$ Lower Spacer (#32)
- two $\Phi 10$ Spring Washers (#74)
- two $\Phi 11 \times \Phi 20 \times 2$ Flat Washers (#72)
- two M10*40 Socket Head Cap Bolts (#80)

Note: Tighten all connections from Step 9.

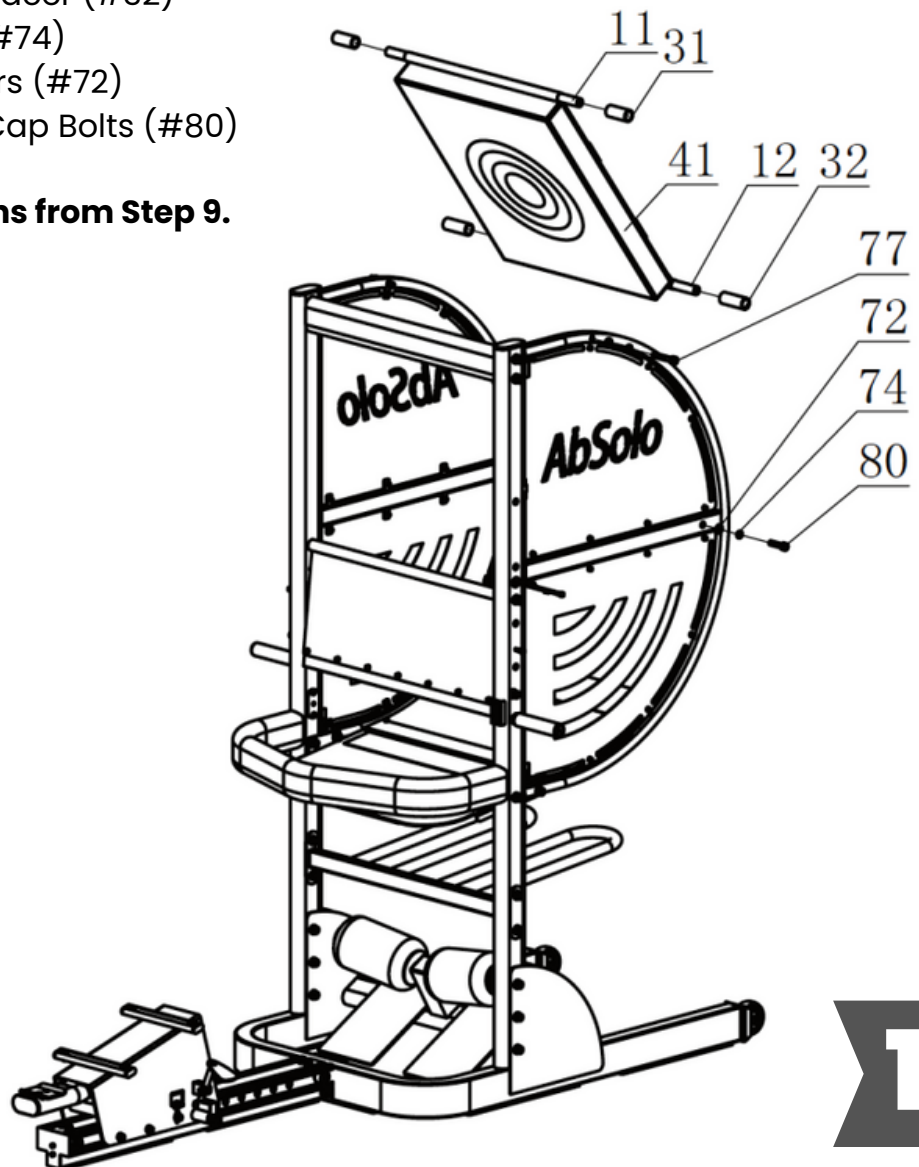



ASSEMBLY

● STEP 10

1. Attach the Inner Baffle (#42) to the back of the Target (#41). four M10*60 Socket Head Cap Bolts (#77)
2. Insert the Chute Cover (#43) inside the Upper Chute (#21). Fold the front edge over the Lower Chute (#9) and secure the velcro. At the back of the unit fold the tail flap over the back of the Upper Chute (#21) and secure the velcro.
3. Attach the Outer Chute (#44) cover by inserting each individual tab through their associated slot (1 in the front and 5 on each side) and then press the tail down on the new velcro strip affixed to the outside of the Chute Cover (#43).

Note: Tighten all connections from Step 10.

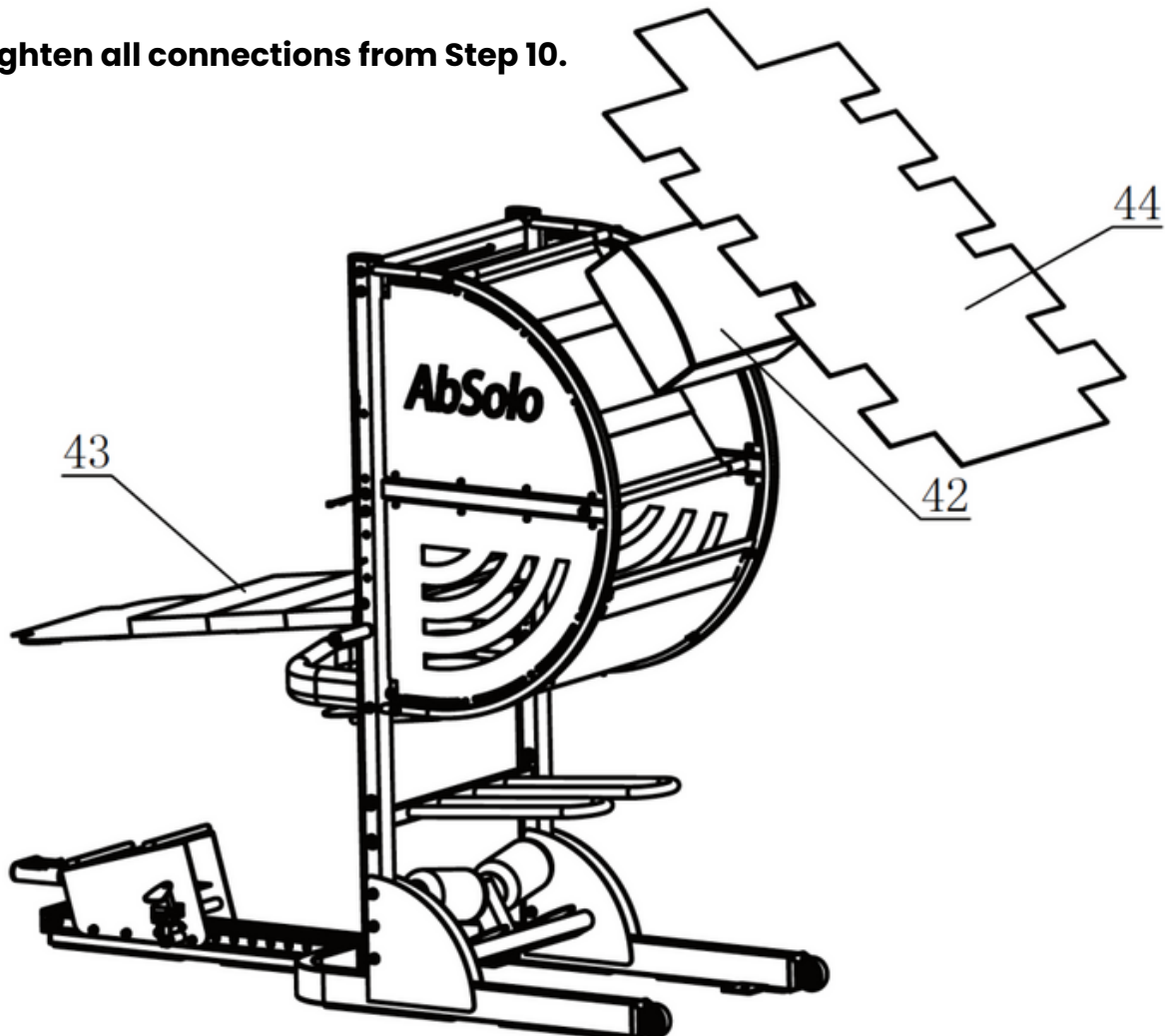



ASSEMBLY

STEP 11

1. Attach the Seat to the Carriage (#14) using:

- four M10*85 Socket Head Cap Bolts (#85)
- four $\Phi 11*\Phi 20*2$ Flat Washers (#72)

2. Attach the Back Support Cushion ASSY (#17) to the back of the Carriage (#14) using:

- two M10*60 Socket Head Cap Bolts (#77)
- two $\Phi 10$ Spring Washers (#74)
- two $\Phi 11*\Phi 20*2$ Flat Washers (#72)

Note: Tighten all connections from Step 11.

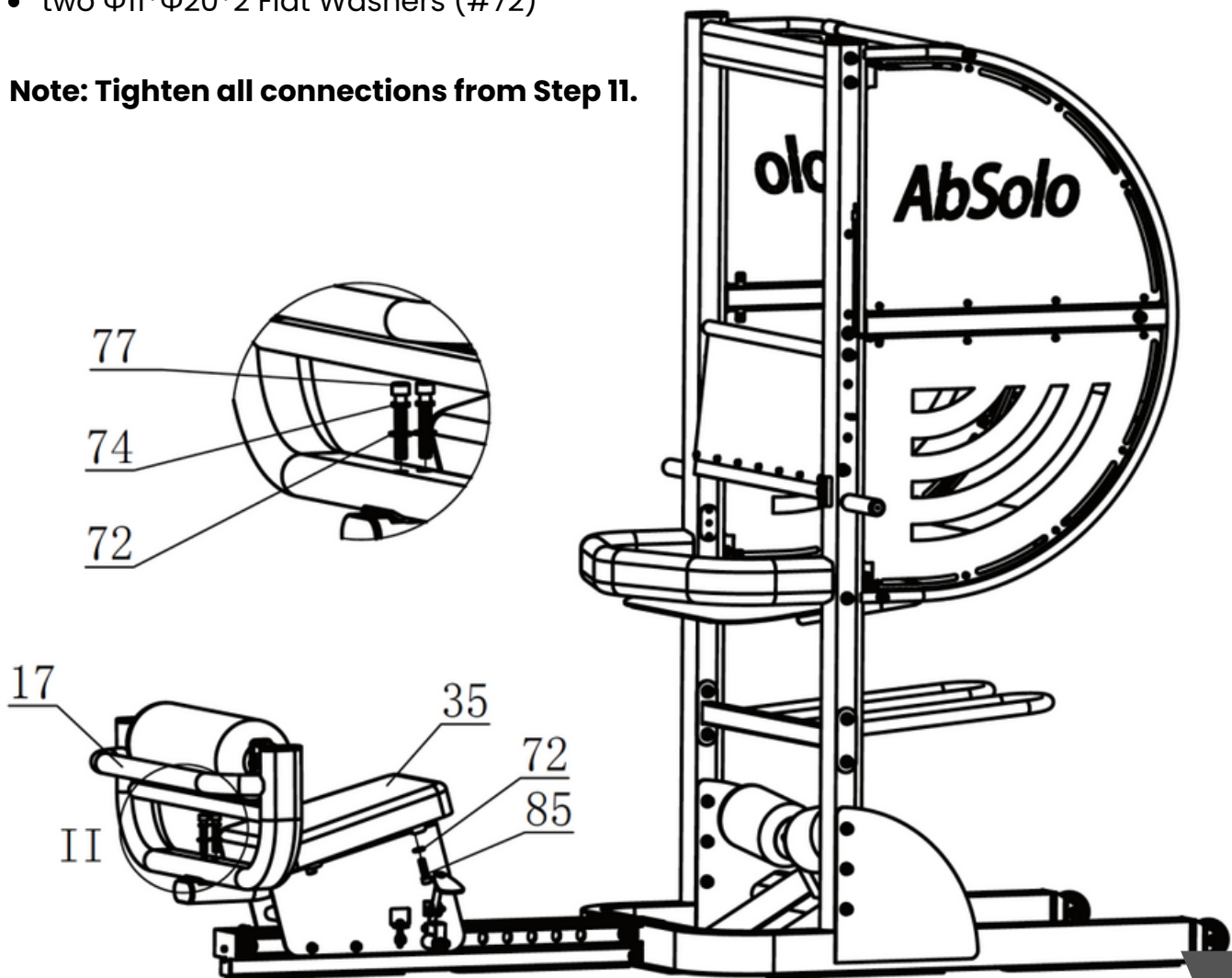



ASSEMBLY

STEP 12

1. Attach the Left & Right Target Plates (#10) using:

- four M8*20 Socket Head Cap Bolts (#86)
- four $\Phi 8$ Spring Washers (#82)
- four $\Phi 9*\Phi 16*1.6$ Flat Washers (#73)

2. Attach the Counter Mount Bracket (#18) using:

- two M8*20 Socket Head Cap Bolts (#86)
- two $\Phi 8$ Spring Washers (#82)
- two $\Phi 9*\Phi 16*1.6$ Flat Washers (#73)

3. Connect the wires from the Upright to the back of the Counter (#52) and then attach the Counter to the Counter Mount Bracket (#18) using:

- four M5*12 Phillips Button Head Bolt (#90)

Note: Tighten all connections from Step 12. Machine is now ready to be moved into place and can be used safely.

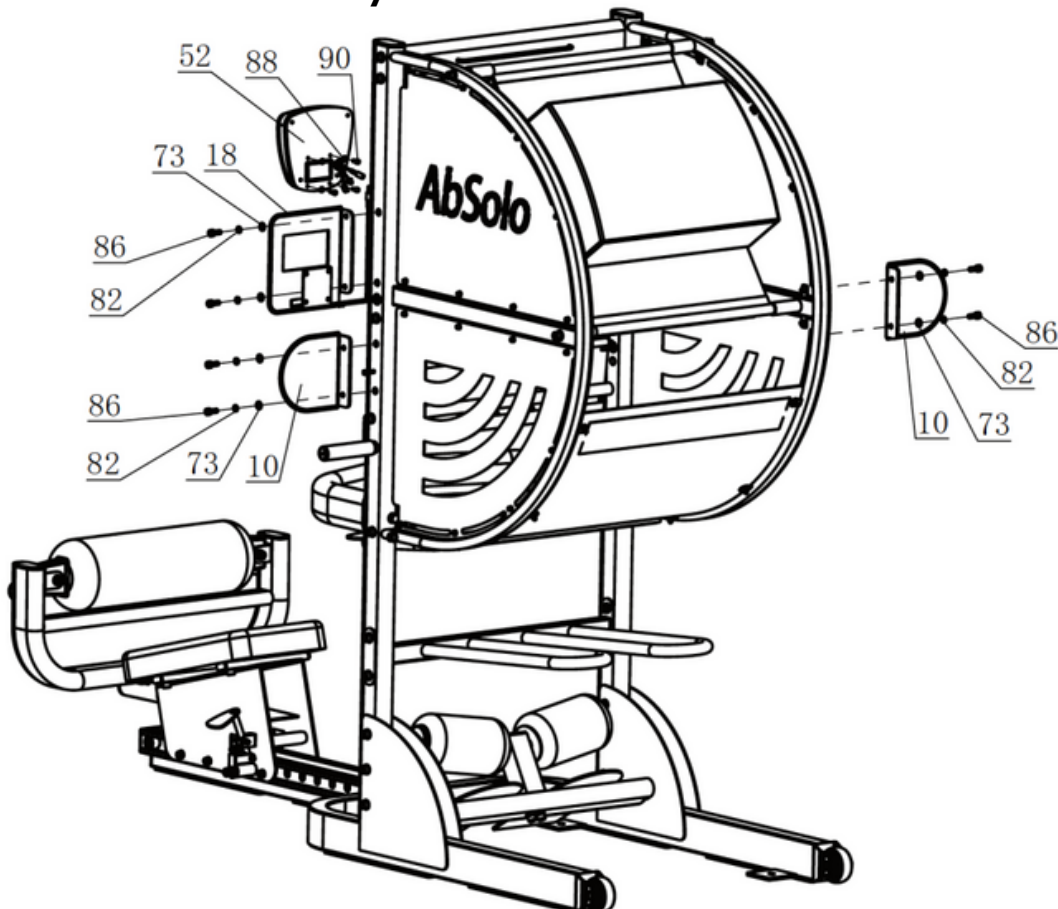

GENERAL MAINTENANCE SCHEDULE

ROUTINE	COMMERCIAL MAINTENANCE	HOME MAINTENANCE	LATEST DATE ENTRY						
Inspect; Links, Pull Pins, Snap Locks, Swivels, Weight Stack Pins	DAILY	WEEKLY							
Clean; Upholstery	DAILY	WEEKLY							
Inspect; Cables or Belts and their tension	DAILY	WEEKLY							
Inspect; Accessory Bars, and Handles	WEEKLY	3 MONTHS							
Inspect; All Decals	WEEKLY	3 MONTHS							
Inspect; All Nuts and Bolts, Tighten if needed	WEEKLY	3 MONTHS							
Inspect; Anti-Skid Surface	WEEKLY	3 MONTHS							
Clean & Lubricate; Guide Rods with a Teflon (PTFE) based lubricant (Supertube)	MONTHLY	3 MONTHS							
Lubricate; Seat Sleeves, Turcite Bushings, Linear Bearing	MONTHLY	3 MONTHS							
Clean and Wax; All Glossy Finishes	6 MONTHS	YEARLY							
Repack with Grease; Linear Bearings	6 MONTHS	YEARLY							
Replace; Cables, Belts and Connecting Parts	YEARLY	3 YEARS							

A fitness facility should have a regular maintenance schedule in place that this equipment can be added into. For personal, in home use, please follow the home maintenance schedule listed above

GENERAL MAINTENANCE INFORMATION



Links, Pull-Pins, Snap Hooks, Swivels, Weight Stack Pins:

- Check all pieces for signs of visible wear or damage.
- Check springs in snap hooks and pull-pins for proper tension and alignment.
- If the spring sticks or has lost its rigidity, replace it immediately.

Upholstery:

- To ensure prolonged upholstery life and proper hygiene, all upholstered pads should be wiped down with a damp cloth after every workout.
- Periodically take the time to use a mild soap or an approved vinyl upholstery cleaner to deter the onset of cracking or drying. Avoid using any abrasive cleaners or cleaners not intended for use on vinyl.
- Replace ripped or worn upholstery immediately.
- Keep sharp or pointed objects clear of all upholstery.

Decals:

- Inspect and familiarize yourself with any safety warnings or other user information posted on each unit.

Nuts and Bolts:

- Inspect all nuts and bolts for any loosening and tighten if needed.
- Go through a re-tightening sequence periodically to ensure that all hardware is tensioned properly.

Anti-Skid Surfaces:

- These surfaces are designed to supply secure footing and need to be replaced if they appear worn or become slippery.

Belts and Cables:

- Visually inspect the belts and cables for fraying, cracking, peeling, or discoloration.
- While the machine is not in use, carefully run your fingers along the belt or cable to feel for thinning or bulging areas.
- Replace belts and cables immediately at the first signs of damage or wear. Do not use equipment until belts or cables have been replaced.

Belt and Cable Tension:

- Referring to the Owners Manual, when belts or cables are used check all bolts attachments to be sure they are properly attached.
- Check slack in cables and re-adjust cable tension if needed.

Seat Sleeves, Guide Rods:

- Before applying lubricant, wipe down applicable parts with a dust free rag.
- Lubricate seat sleeves and Guide Rods with a Silicon or Teflon based lubricant spray.

Linear Bearings:

- Referring to the Owners Manual carefully disassemble the bearing from its housing and place a finger full of light grease (lithium, super lube, etc.) into the inside of the bearing. Using your finger, press the grease into the ball-bearings and their tracks. Repeat until the ball-bearing tracks are full of grease. Insert the shaft back into the bearing and wipe off excess grease.



TRAINING TIPS

Use this manual to guide you through the basic exercises you can perform on your equipment. To gain maximum results and avoid possible injury, consult a fitness professional to develop your complete exercise program.

Always consult your physician before starting any exercise program.

To be successful in your exercise program, it is important to develop an understanding of the basic principles of strength training. Now that you have your equipment, it is only natural that you want to get started immediately. First, determine a set of realistic goals and objectives for yourself. By deciding on an exercise plan that is right for you prior to starting, you will contribute significantly to your success.

Warm up properly before engaging in weight resistance training. Stretching, yoga, jogging, calisthenics or other cardiovascular exercise can help prepare your body for the heavier workload of lifting weights.

Learn how to perform the exercise correctly before using heavy weight. Correct form is important to avoid injury and to ensure that you work the proper muscle groups.

Know your limitations. If you are new to weight training or are embarking on an exercise regimen after a long layoff, start slowly and build foundational strength over a longer period of time.

Pay attention to your breathing. Exhale when you exert is a general rule of thumb. Never hold your breath.



Manufacturer's Limited Warranty

The manufacturer warrants that your **AbSolo®** is free of defect in materials and workmanship and will, at its option, repair or replace any defective **AbSolo®** that is returned to it. Except as described in the following sentence, all parts and components of the **AbSolo®** are warranted from the original date of purchase as below:

Frame - 3 years

Electronics, Canvas Covers, Throw Target, & Air Filled Seat Bumper - 1 year

6lb & 8lb Balls - 6 months

Padding & Grips - 90 days

All other parts - 1 year

This warranty is valid only in accordance with the condition set forth below:

1. Normal wear and tear (including lost parts) are not covered by this warranty.
2. Only use TAC supplied Medicine balls with the AbSolo. Using other balls will void the warranty.
3. The warranty extends only to the original consumer purchaser and is not transferable. In addition, proof of purchase must be demonstrated. This warranty is void if the product has been subject to accident, misuse, abuse, improper maintenance or repair or unauthorized modification.
4. This limited warranty is the only written or express warranty given by the manufacturer. Any implied warranty of merchantability of fitness for a particular purpose on this product is limited in duration to the duration of this warranty. Some states do not allow limitations on how long an implied warranty lasts, so the above limitation may not apply to you.
5. Repair or replacement of the product (or, if repair or replacement is not feasible, a refund of the purchase price) is the exclusive remedy of the consumer under this warranty. The manufacturer reserves the right to remedy any warranty claims via parts and repair prior to replacement. The manufacturer shall not be liable for any incidental or consequential damages for breach of this warranty or any implied warranty on this product. Some states do not allow the exclusion or limitation of incidental or consequential damages, so the above limitation or exclusion may not apply to you.
6. This warranty gives you specific legal rights, and you may also have other rights which vary from state to state.

Procedure for Warranty Repairs or Replacement:

If warranty service is necessary, the original purchaser must either call or email for instructions.

Proof of Purchase will be required for all warranty claims.

Our phone number is: (866) 219-5335 x0 (outside the U.S. 1-908-879-2713 x0)

www.theabscompany.com

info@theabscompany.com

AbSolo®

Thank you for purchasing the AbSolo
Our customer service staff is ready to help
and to answer any questions
Our phone number is: (866) 219-5335 x 5
Support@TheAbsCompany.com

Please call us if you have any questions.
Customer service staff can be reached
Monday to Friday from 9:00 AM to 5:00 PM Eastern Standard Time.

You can also send us an email, or visit our website
for additional customer service information.

Prior to calling or emailing, please have the following information ready:

- Customer Name and Address
 - Telephone Number
 - Proof of Purchase
- Product Model Number
 - Serial Number



We Change Lives from the Core

The Abs Company, 8429 Lorraine Rd, Lakewood Ranch, FL 34202
1-866-219-5335 - www.TheAbsCompany.com
© 2022 The Abs Company. All Rights Reserved.

Protected under US and INTERNATIONAL Patents. Patent information available upon request.