

Owners Manual

Model #ABS2003B

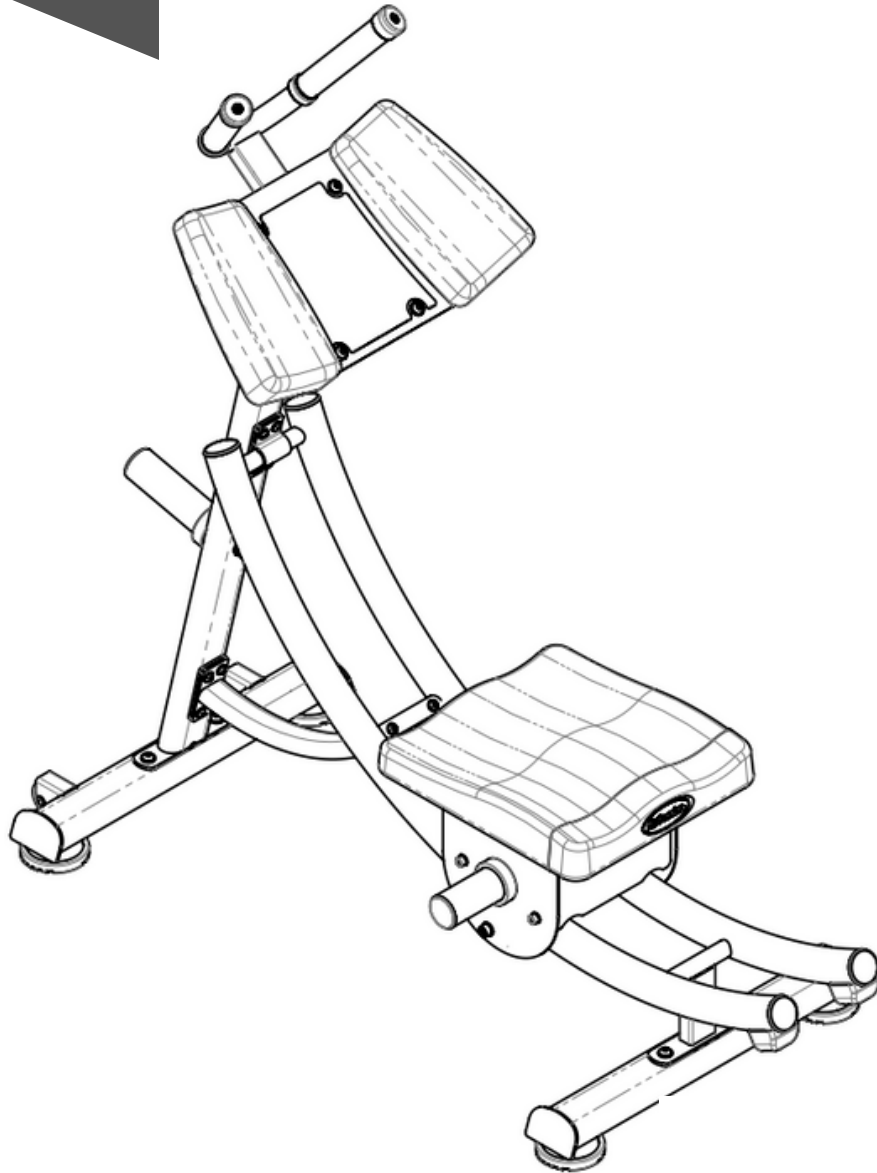

We Change Lives from the Core

Warranty information inside



TABLE OF CONTENTS

Important Safety Instructions.....	pg. 03
Instructions.....	pg. 04
Parts List.....	pg. 05
Exploded View.....	pg. 06
Hardware Kit.....	pg. 07
Measurement Guide.....	pg. 08
Assembly Instruction.....	pg. 09
Assembly.....	pg. 10
General Maintenance Schedule.....	pg. 14
General Maintenance Information.....	pg. 15
Training Tips.....	pg. 16
Warranty.....	pg. 17



CAUTION Read all precautions and instructions in the manual before using this equipment.

IMPORTANT SAFETY INSTRUCTIONS



Before beginning any fitness program, you should obtain a complete physical examination from your physician. When using exercise equipment, basic precautions should always be taken, including the following:

1. Read all instructions before using the equipment. These instructions are written to ensure your safety and to protect the unit.
2. Use the equipment only for its intended purpose as described in this guide. Do not use accessory attachments that are not recommended by the manufacturer, as such attachments might cause injuries.
3. The product should only be used on a level surface and with 0.5 meters space around the product. Do not store the equipment outdoors.
4. The equipment is not intended for use by children under the age of 16. Children over the age of 16 should use the equipment with adult supervision.
5. Do not overexert yourself or work to exhaustion. Do not attempt to lift more weight than you can control safely. If you feel any pain or abnormal symptoms, stop your workout immediately and consult your physician.
6. This equipment is not intended to be used as or with medical apparatus/instruments.
7. Never operate the unit when it has been dropped or damaged. Never drop or insert anything into any opening in the equipment. Always check the unit and its cables before each use. Make sure that all fasteners and cables are secure and in good working condition. Frayed or worn cables can be dangerous and may cause injury. Periodically check these cables for any indication of wear. Keep hands, limbs, loose clothing and long hair well out of the way of moving parts.
8. Be careful when getting on or off the equipment.
9. Wear proper exercise clothing and shoes for your workout, no loose clothing.

Personal Safety During Assembly

Read each step in the assembly instructions and follow the steps in sequence. Do not skip ahead. If you skip ahead, you may learn later that you have to disassemble components and that you may have damaged the equipment.

Assemble and operate the equipment on a solid, level surface. Locate the unit a few feet from walls or furniture to provide easy access. The equipment is designed for your enjoyment, and by following these precautions, we believe you will enjoy your new equipment and the many benefits it will provide.



INSTRUCTIONS

Before beginning assembly, please take the time to read instructions thoroughly. Please use the various lists in this manual to make sure that all parts have been included in your shipment. If parts are found to be missing, please contact either your authorized dealer or us directly and reference the part name and number from the parts list. Use only our replacement part when servicing. Failure to do so will void your warranty and could result in personal injury.

The equipment is designed to provide the smoothest, most effective exercise motion possible. After assembly, you should check all functions to ensure correct operation. If you experience problems, first recheck the assembly instructions to locate any possible errors made during assembly. If you are unable to correct the problem, call your authorized dealer or contact us directly to continue troubleshooting. Be sure to have the serial number, related part names and numbers and your manual handy when calling. Do not continue assembly, or use the equipment until all parts have been accounted for and troubleshooting is complete.

Tools Required



Ratchet Wrench and Socket



Adjustable Wrench

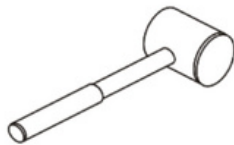

Rubber Mallet



Hex Key Wrench set



Phillips Screwdriver

PARTS LIST



NOTE: SOME OF THESE PARTS MAY COME PRE-INSTALLED

Item No.	Description	Qty	Item No.	Description	Qty
1	Front Foot Frame ASSY	1	29	Instruction Decal	1
2	Rear Foot Frame ASSY	1	30	Φ48 End Cap	3
3	Front Frame ASSY	1	31	Φ50 End Cap	4
4	Rail ASSY	1	32	Φ32 Handle Ring	2
5	Faceplate	1	33	Φ32 End Cap	2
6	Seat Carriage ASSY	1	34	Handlebar Grip	2
7	Seat Support Frame ASSY	1	35	Rail Bumpers	2
8	Diagonal Brace	1	36	Label	1
9	Weight Storage Post ASSY	1	37	M6*15 Bolt	7
10	Bottom Plate	4	38	M8*15 Socket Head Cap Bolt	12
11	Sleeving	1	39	M8*25 Bolt	2
12	Bushing	2	40	M8*25 Socket Head Cap Bolt	2
13	Bearing Sleeve	4	41	M8*45 Bolt	4
14	Φ8 Bushing	8	42	M8*85 Bolt	4
15	Sleeving	2	43	M10*20 Socket Head Cap Bolt	18
16	Washer Φ37*Φ17*3	1	44	M10*65 Socket Head Cap Bolt	1
17	Bigger Washer Φ42.6*Φ25.2	1	45	M10*75 Bolt	2
18	Rubber Pad	4	46	M6*4 Bolt	2
19	Movement Wheel Φ37*Φ17*3	2	47	Φ6.6*Φ12*1.6 Flat Washer	7
20	Wheel Φ50*Φ22*60	4	48	Φ9*Φ16*1.6 Flat Washer	30
21	Small Wheel Φ38.5*Φ19*51	2	49	Φ11*Φ20*12 Flat Washer	27
22	Bushing Φ17*Φ3.5*30	1	50	Φ10 Spring Washer	1
23	Cushion Pad	2	51	M8 Nut	8
24	Weight Post Collar	3	52	M10 Nut	8
25	Cushion Collar	2	53	M16 Nut	1
26	Seat Pad	1	54	M16 Lock Nut	1
27	Forearm Pad	2	55	Bearing	4
28	Seat Guard	1	56	Bearing	8



EXPLODED VIEW

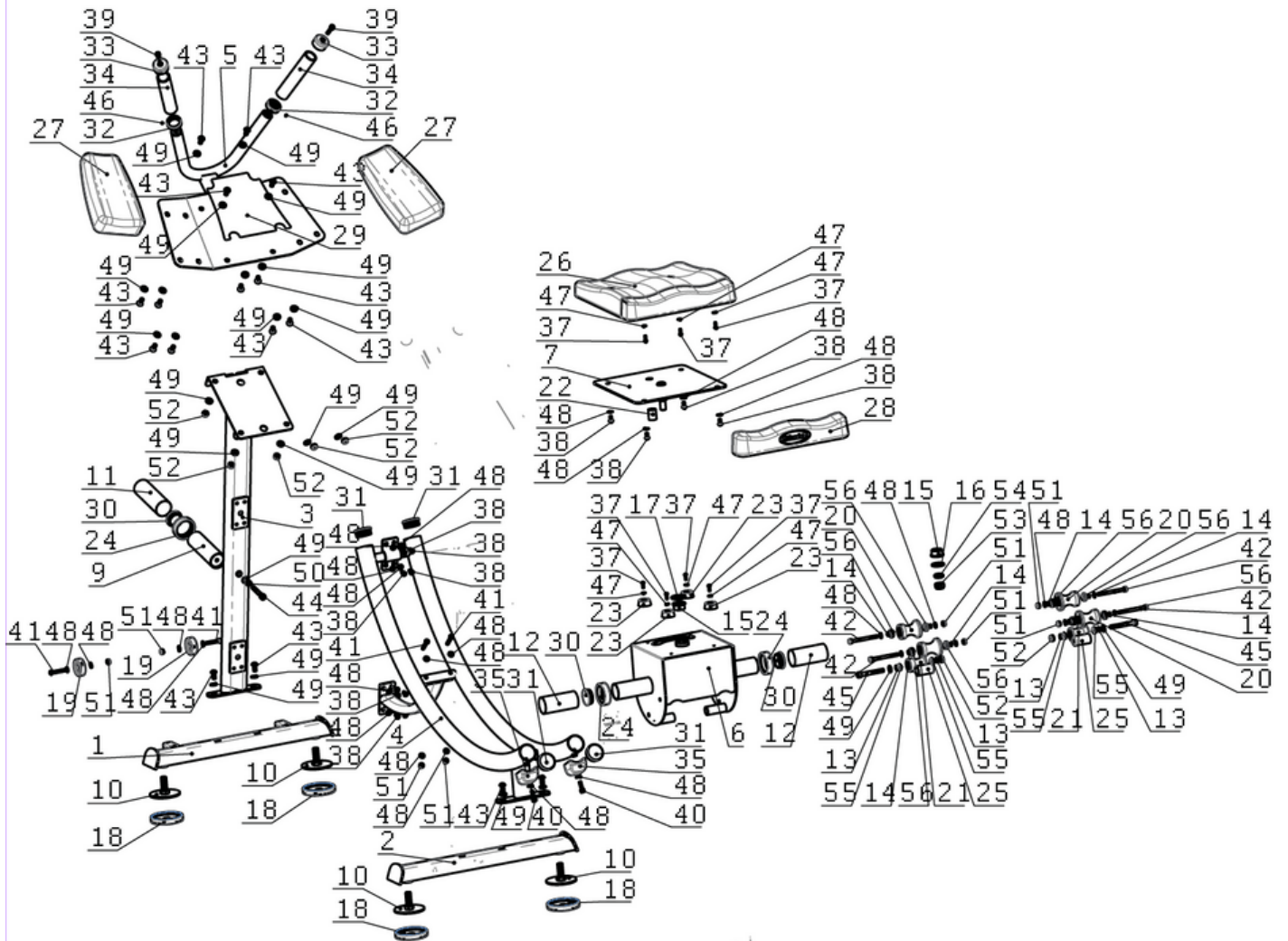

HARDWARE KIT



PARTS

- No. 44 M10X20 (18)
- No. 39 M8X15 (12)
- No. 49 Ø8 Washer (18)
- No. 40 M8X25 (2)
- No. 52 M8 Nut (2)
- No. 50 Ø10 Washer (25)
- No. 45 M10X65 (1)
- No. 51 Ø10 Spring Washer (1)
- No. 42 M8X45 (2)
- No. 53 M10 Nut (6)
- Allen Wrench 5mm
- Allen Wrench 6mm
- Allen Wrench 8mm
- Universal Wrench

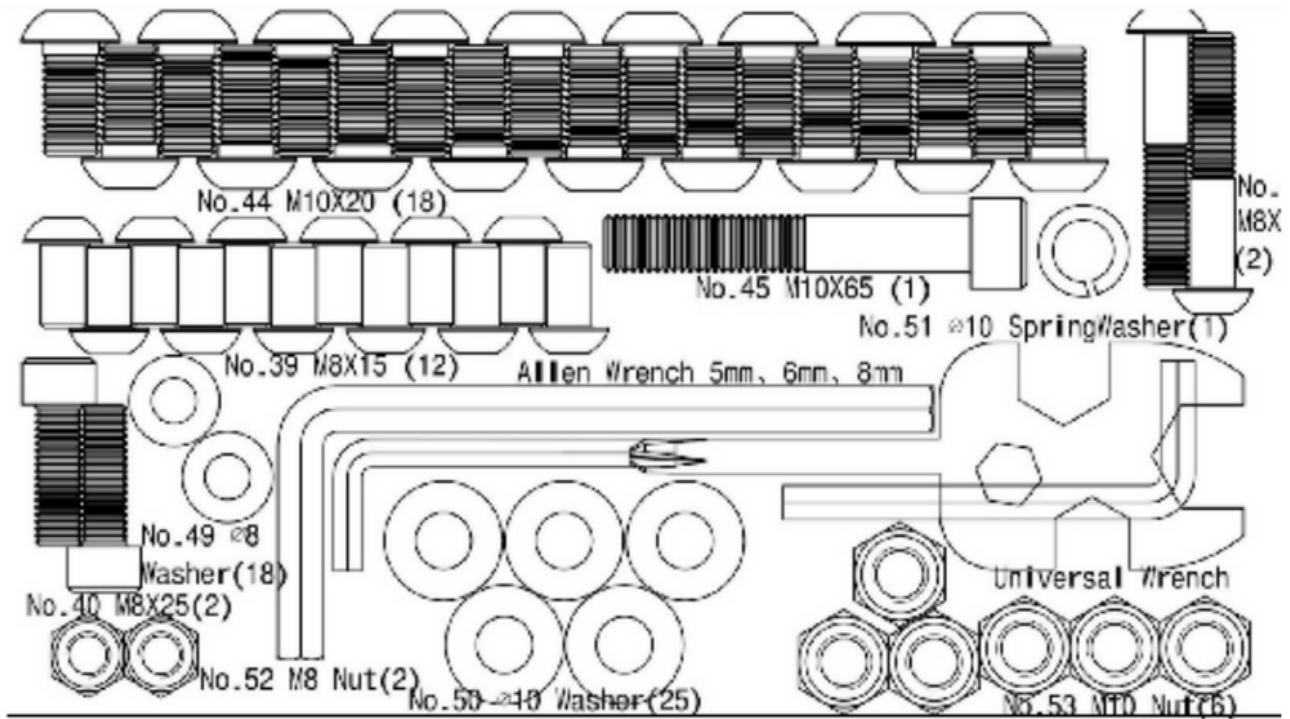

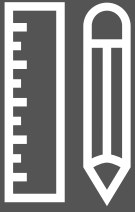

MEASUREMENT GUIDE

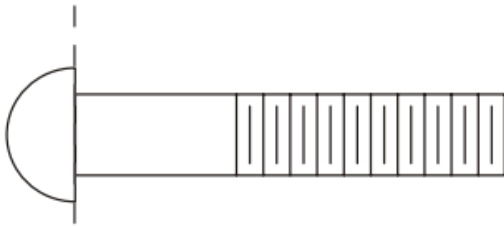

BHCB = Button Head Cap Bolt

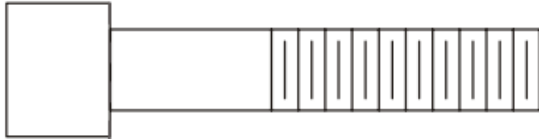

SHCB = Socket Head Cap Bolt

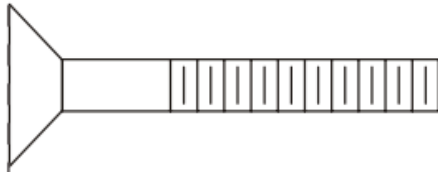

FHCB = Flat Head Cap Bolt

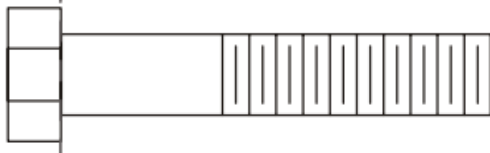

HHB = Hex Head Bolt

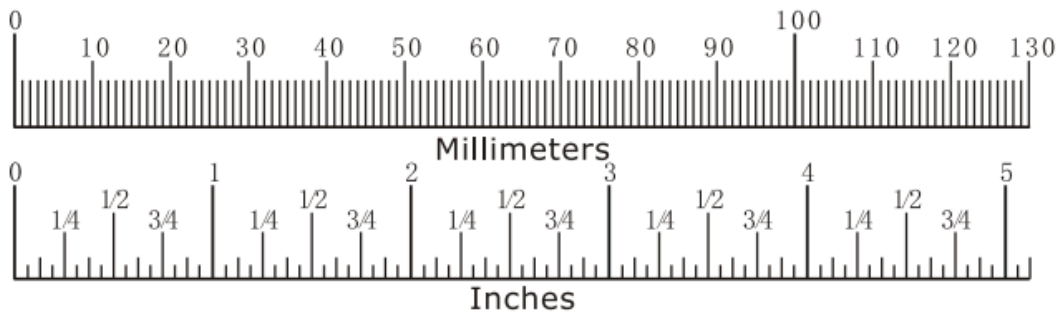

Diameter of bolt (mm/inch)	M6(1/4")	M8(5/16")	M10(3/8")	M12(1/2")	M16(5/8")
Tightening torque (N.m)	9~12	22~30	45~59	78~104	193~257
Operational methods for an adult	The strength of the wrist	The strength of the wrist and forearm	The strength of the entire arm	The strength of the arm and upper body	with all strength

ASSEMBLY INSTRUCTIONS



Assembly of the equipment takes professional installers about 2 hours. If this is the first time you have assembled this type of equipment, plan to spend more time. If you are in doubt about any part of this assembly, we recommend you contact a professional installer to complete the assembly. You may find it quicker, safer, and easier to assemble this equipment with the help of an assistant, as some components may be large, heavy or awkward to handle alone. It is important that you assemble your product in a clean, clear, uncluttered area. This will enable you to move around the product while you are fitting components and reduce the possibility of injury during assembly or damage to the area or equipment.



Note

As with any assembled part, proper alignment and adjustment is critical. While tightening the fasteners, be sure to leave room for adjustments. Do not fully tighten the fasteners until instructed to do so. Be careful to assemble the components in the sequence presented in this guide.

Training Area and Free Area

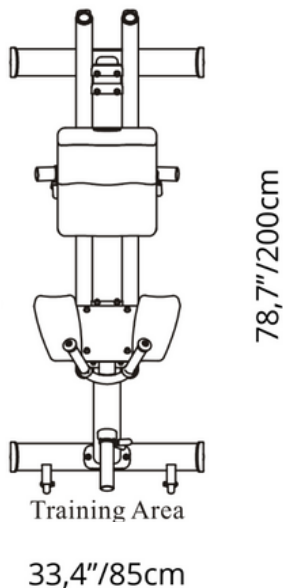

Free Area

Please allow for free area beyond the training area of 24 in / 60 cm on all sides of the unit to ensure that the training area is not impeded.

Specifications

Maximum Wt. Capacity: 220 lbs / 100 kg Maximum User Weight: 330 lbs / 150 kg Product Total Surface: 54*23.4 in / 137*59.5 cm



ASSEMBLY

● STEP 1

1. Thread the Seat Carriage ASSY(#6) onto the Rail ASSY (#4).
2. Attach two Rail Bumpers (#35) to the Rail ASSY (#7) using:
 - two M8*25 Socket Head Cap Bolt (#40)
 - two $\Phi 9*\Phi 16*1.6$ Flat Washer (#48)

Note: Tighten all connections from Step 1.

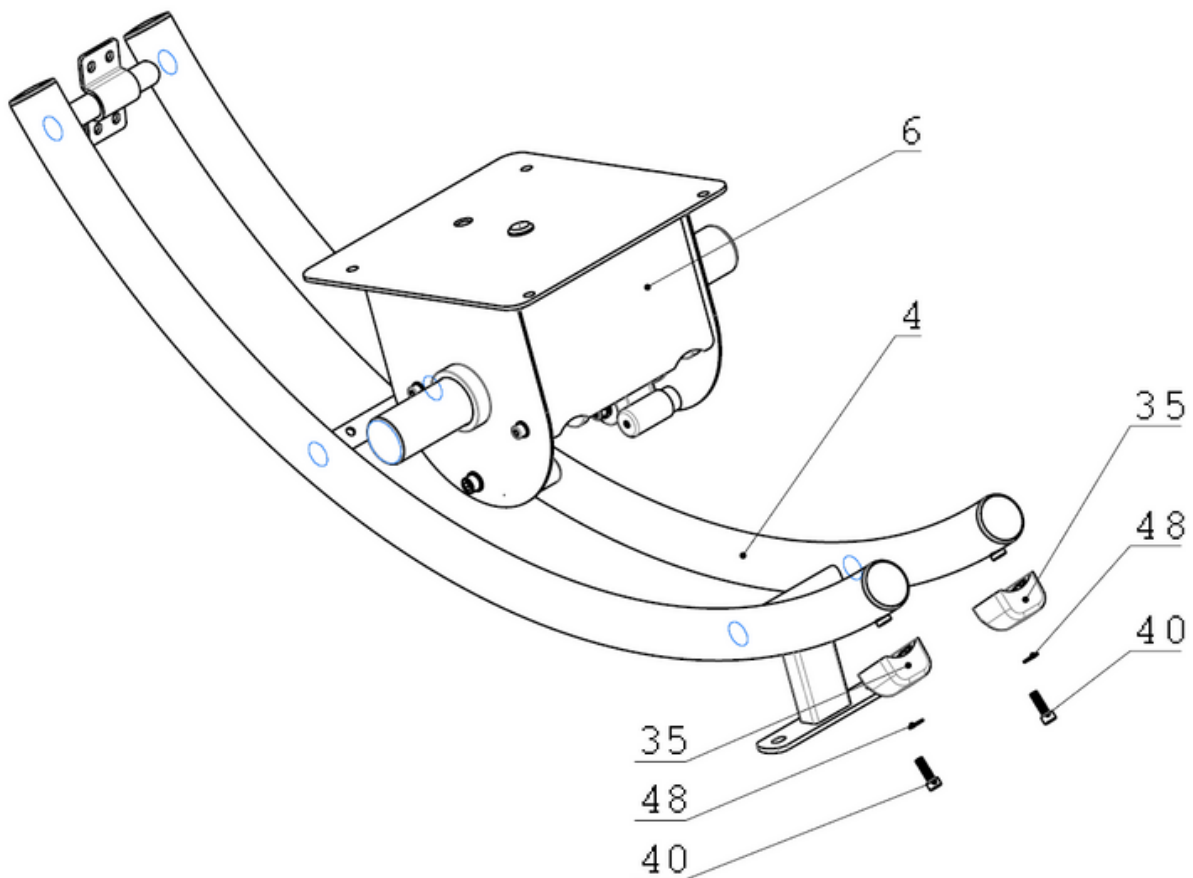



STEP 2

1. Attach the Front Foot Frame ASSY (#1) to the Front Frame ASSY (#3) using:
 - two M10*20 Socket Head Cap Bolt (#43)
 - two $\Phi 11*\Phi 20*2$ Flat Washer (#49)
2. Attach the Rear Foot Frame ASSY (#2) to the Rail ASSY (#4) using:
 - two M10*20 Socket Head Cap Bolt (#43)
 - two $\Phi 11*\Phi 20*2$ Flat Washer (#49)
3. Attach the Rail ASSY (#4) to the Front Frame ASSY (#3) using:
 - four M8*15 Socket Head Cap Bolt (#38)
 - four $\Phi 9*\Phi 16*1.6$ Flat Washer (#48)

Note: Tighten all connections from Step 2.

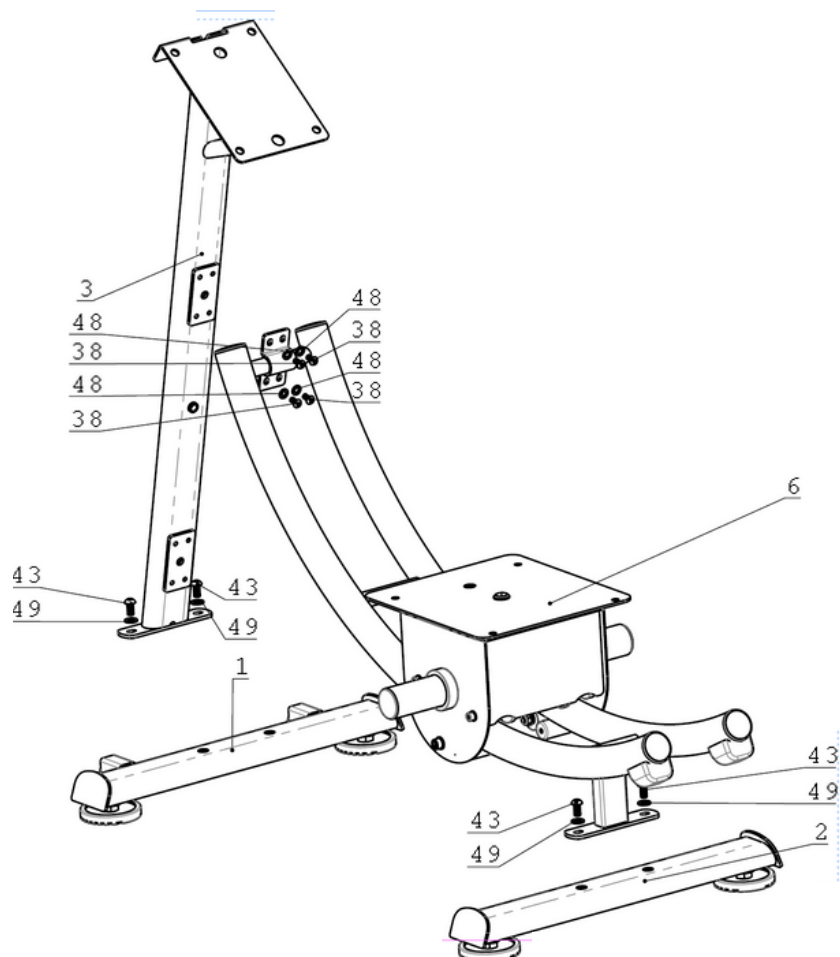



ASSEMBLY

● STEP 3

1. Attach the Diagonal Brace (#8) to the Front Frame ASSY (#3) and Rail ASSY (#4) using:

- four M8*15 Socket Head Cap Bolt (#38)
- eight $\Phi 9*\Phi 16*1.6$ Flat Washer (#48)
- two M8*45 Socket Head Cap Bolt (#41)
- two M8 Nut (#51)

2. Attach the Faceplate ASSY (#5) to the Front Frame ASSY (#3) using:

- six M10*20 Socket Head Cap Bolt (#43)
- twelve $\Phi 11*\Phi 20*2$ Flat Washer (#49)
- six M10 Nut (#52)

Note: There are 4 bolts on top of the face plate AND 2 more on the front of the face plate located on either side of the handlebar weld point above the AbCoaster logo. All 6 bolts are essential. Once complete, Tighten all connections from Step 3.

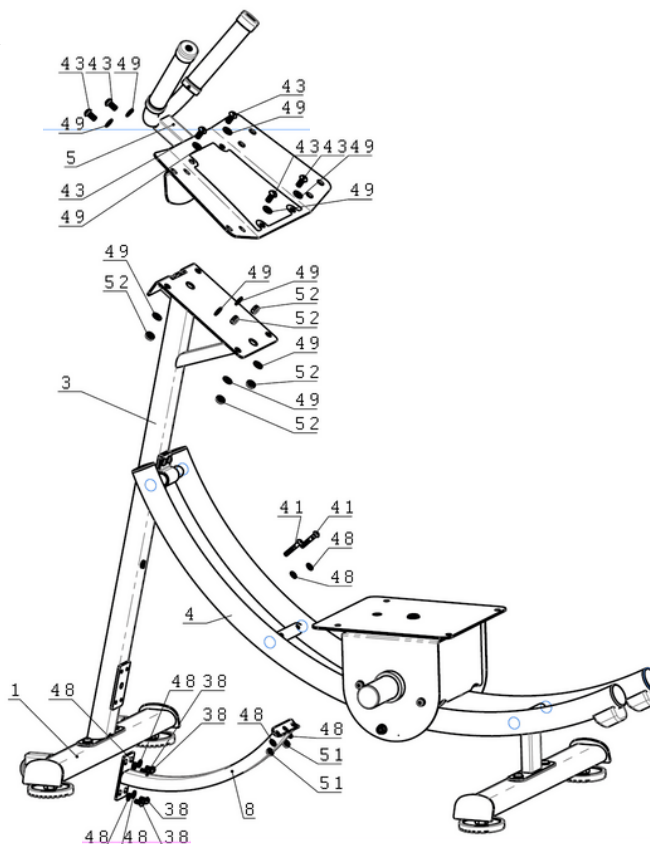



STEP 4

1. Attach the Forearm Pad (#27) to the Faceplate ASSY (#11) using:
 - eight $\Phi 11 \times \Phi 20 \times 2$ Flat Washer (#49)
 - eight M10*20 Socket Head Cap Bolt (#43)
2. Attach the Seat Pad (#26) to the Seat Carriage ASSY (#6) using:
 - four M8*15 Socket Head Cap Bolt (#38)
 - four $\Phi 9 \times \Phi 16 \times 1.6$ Flat Washer (#48)
3. Attach the Weight Storage Post (#9) to the Frame ASSY (#3) using:
 - one M10*65 Socket Head Cap Bolt (#44)
 - one $\Phi 11 \times \Phi 20 \times 2$ Flat Washer (#49)
 - one $\Phi 10$ Spring Washer (#50)

Note: Tighten all connections from Step 4. Machine is now ready to be moved into place and can be used safely

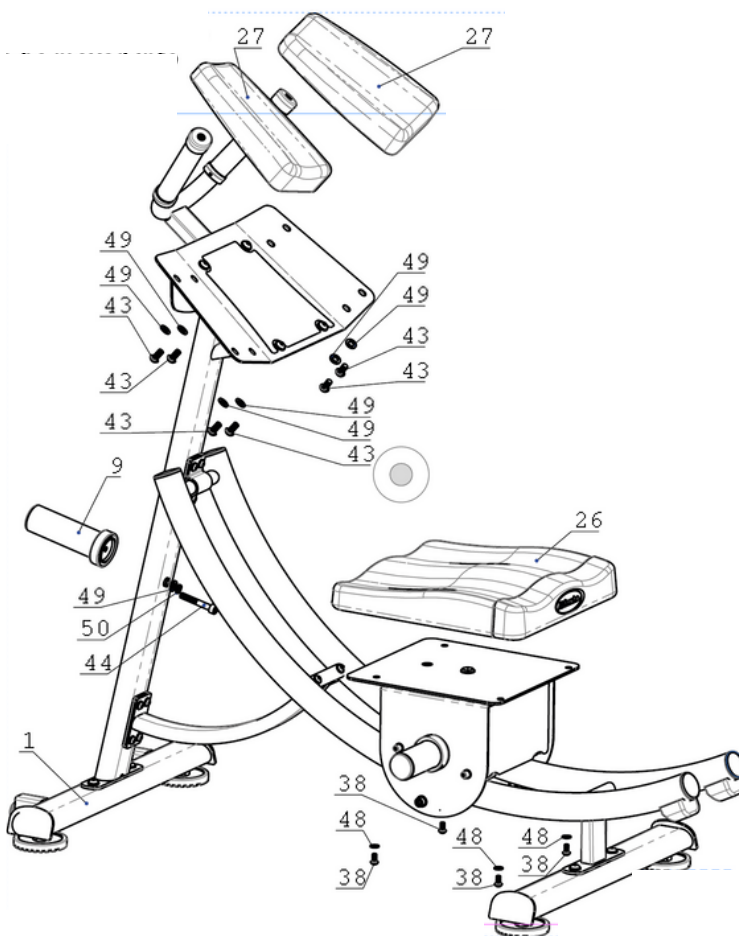

GENERAL MAINTENANCE SCHEDULE



ROUTINE	COMMERCIAL MAINTENANCE	HOME MAINTENANCE	LATEST DATE ENTRY						
Inspect; Links, Pull Pins, Snap Locks, Swivels, Weight Stack Pins	DAILY	WEEKLY							
Clean; Upholstery	DAILY	WEEKLY							
Inspect; Cables or Belts and their tension	DAILY	WEEKLY							
Inspect; Accessory Bars, and Handles	WEEKLY	3 MONTHS							
Inspect; All Decals	WEEKLY	3 MONTHS							
Inspect; All Nuts and Bolts, Tighten if needed	WEEKLY	3 MONTHS							
Inspect; Anti-Skid Surface	WEEKLY	3 MONTHS							
Clean & Lubricate; Guide Rods with a Teflon (PTFE) based lubricant (Supertube)	MONTHLY	3 MONTHS							
Lubricate; Seat Sleeves, Turcite Bushings, Linear Bearing	MONTHLY	3 MONTHS							
Clean and Wax; All Glossy Finishes	6 MONTHS	YEARLY							
Repack with Grease; Linear Bearings	6 MONTHS	YEARLY							
Replace; Cables, Belts and Connecting Parts	YEARLY	3 YEARS							

A fitness facility should have a regular maintenance schedule in place that this equipment can be added into. For personal, in home use, please follow the home maintenance schedule listed above.



ASSEMBLY

Links, Pull-Pins, Snap Hooks, Swivels, Weight Stack Pins:

- Check all pieces for signs of visible wear or damage.
- Check springs in snap hooks and pull-pins for proper tension and alignment.
- If the spring sticks or has lost its rigidity, replace it immediately.

Upholstery:

- To ensure prolonged upholstery life and proper hygiene, all upholstered pads should be wiped down with a damp cloth after every workout.
- Periodically take the time to use a mild soap or an approved vinyl upholstery cleaner to deter the onset of cracking or drying. Avoid using any abrasive cleaners or cleaners not intended for use on vinyl.
- Replace ripped or worn upholstery immediately.
- Keep sharp or pointed objects clear of all upholstery.

Decals:

- Inspect and familiarize yourself with any safety warnings or other user information posted on each unit.

Nuts and Bolts:

- Inspect all nuts and bolts for any loosening and tighten if needed.
- Go through a re-tightening sequence periodically to ensure that all hardware is tensioned properly.

Anti-Skid Surfaces:

- These surfaces are designed to supply secure footing and need to be replaced if they appear worn or become slippery.

Belts and Cables:

- Visually inspect the belts and cables for fraying, cracking, peeling, or discoloration.
- While the machine is not in use, carefully run your fingers along the belt or cable to feel for thinning or bulging areas.
- Replace belts and cables immediately at the first signs of damage or wear. Do not use equipment until belts or cables have been replaced.

Seat Sleeves, Guide Rods:

- Before applying lubricant, wipe down applicable parts with a dust free rag.
- Lubricate seat sleeves and Guide Rods with a Silicon or Teflon based lubricant spray.

Linear Bearings:

- Referring to the Owners Manual carefully disassemble the bearing from its housing and place a finger full of light grease (lithium, super lube, etc.) into the inside of the bearing. Using your finger, press the grease into the ball-bearings and their tracks. Repeat until the ball-bearing tracks are full of grease. Insert the shaft back into the bearing and wipe off excess grease.

Training Tips



Use this manual to guide you through the basic exercises you can perform on your equipment. To gain maximum results and avoid possible injury, consult a fitness professional to develop your complete exercise program.

Always consult your physician before starting any exercise program.

To be successful in your exercise program, it is important to develop an understanding of the basic principles of strength training. Now that you have your equipment, it is only natural that you want to get started immediately. First, determine a set of realistic goals and objectives for yourself. By deciding on an exercise plan that is right for you prior to starting, you will contribute significantly to your success.

Warm up properly before engaging in weight resistance training. Stretching, yoga, jogging, calisthenics or other cardiovascular exercise can help prepare your body for the heavier workload of lifting weights.

Learn how to perform the exercise correctly before using heavy weight. Correct form is important to avoid injury and to ensure that you work the proper muscle groups.

Know your limitations. If you are new to weight training or are embarking on an exercise regimen after a long layoff, start slowly and build foundational strength over a longer period of time.

Pay attention to your breathing. Exhale when you exert is a general rule of thumb. Never hold your breath.



Manufacturer's Limited Warranty

The manufacturer warrants that your **AbCoaster® CS1500** is free of defect in materials and workmanship and will, at its option, repair or replace any defective **AbCoaster® CS1500** that is returned to it. Except as described in the following sentence, all parts and components of the **AbCoaster® CS1500** are warranted from the original date of purchase as below:

Frame - 3 years
Carriage Rollers & Bumper - 9 Months
Padding & Grips - 90 days
All Other Parts - 1 year

This warranty is valid only in accordance with the condition set forth below:

1. Normal wear and tear (including lost parts) are not covered by this warranty.
2. The warranty extends only to the original consumer purchaser and is not transferable. In addition, proof of purchase must be demonstrated. This warranty is void if the product has been subject to accident, misuse, abuse, improper maintenance or repair or unauthorized modification.
3. This limited warranty is the only written or express warranty given by the manufacturer. Any implied warranty of merchantability of fitness for a particular purpose on this product is limited in duration to the duration of this warranty. Some states do not allow limitations on how long an implied warranty lasts, so the above limitation may not apply to you.
4. Repair or replacement of the product (or, if repair or replacement is not feasible, a refund of the purchase price) is the exclusive remedy of the consumer under this warranty. The manufacturer reserves the right to remedy any warranty claims via parts and repair prior to replacement. The manufacturer shall not be liable for any incidental or consequential damages for breach of this warranty or any implied warranty on this product. Some states do not allow the exclusion or limitation of incidental or consequential damages, so the above limitation or exclusion may not apply to you.
5. This warranty gives you specific legal rights, and you may also have other rights which vary from state to state.

Procedure for Warranty Repairs or Replacement:

If warranty service is necessary, the original purchaser must either call or email for instructions.

Proof of Purchase will be required for all warranty claims.

Our phone number is: (866) 219-5335 x0 (outside the U.S. 1-908-879-2713 x0)

www.theabscompany.com

info@theabscompany.com



Thank you for purchasing the AbCoaster® CS1500
Our customer service staff is ready to help
and to answer any questions.
Our phone number is: (866) 219-5335 x-0
Parts@TheAbsCompany.com

Please call us if you have any questions.
Customer service staff can be reached
Monday to Friday from 9:00 AM to 5:00 PM Eastern Standard Time.

You can also send us an email, or visit our website
for additional customer service information.

Prior to calling or emailing,
please have the following information with you:

- Customer Name and Address
 - Telephone Number
 - Proof of Purchase
- Product Model Number



We Change Lives from the Core

The Abs Company, 8429 Lorraine Rd, Lakewood Ranch, FL 34202
1-866-219-5335 - www.TheAbsCompany.com
© 2022 The Abs Company. All Rights Reserved.

Protected under US and INTERNATIONAL Patents. Patent information available upon request.